

**AGENDA**  
**Dallas Center City Council**  
**April 9, 2019 –7:00 pm – Memorial Hall**

1. Pledge of Allegiance
2. Roll call
3. Action to approve agenda
4. Action to approve consent agenda
  - a. Approve minutes of March 12<sup>th</sup> regular meeting
  - b. March Treasurer's Report, Cash Report, Function Report
  - c. March Law Enforcement, Fire/Rescue, Compliance and Water Reports
  - d. Approve hiring skating rink operator Jill Bejarno and Brianne Kiley at \$12.00/hr effective May 1, 2019 pending background checks
  - e. Approve hiring assistant manager at \$12.00/hr. while acting as asst. manager – Graceann Kruse; 3<sup>rd</sup> year lifeguards at \$8.50/hr – Graceann Kruse, Tatum Jarboe; 2<sup>nd</sup> year lifeguard at \$8.25/hr – Sydney Anderson, Luke Busby, Cameron DeRoos, Lara Kallem, Jaxon Kaster, Pace Langenfeld, Ashley Perkins, Jillian Rants, Alexa Riesselman, Zoey Ross; 1<sup>st</sup> year lifeguards at \$8.00/hr – Audrey Anderson, Annalise Christiansen, Hannah Little, Olivia Macumber, Rachel Neumann, Taylor Wickman; all hires pending lifeguard certification and background checks with start date of May 1, 2019
  - f. Approve hiring Kathy Pantzar as a part-time library assistant at \$10.00./hr effective April 18, 2019, pending background check
  - g. Approve reappointment of JoAnne Ramaeker to the Board of the Dallas County Local Housing Trust Fund, Inc. to represent the City of Dallas Center, three-year term expires February, 2022
  - h. Approve Seasonal Fun Committee street closing for April 20<sup>th</sup> Easter Egg Hunt
  - i. Approve Twisted Corn outdoor liquor license, beer garden and street closing for May 4<sup>th</sup> event
  - j. Approve Twisted Corn outdoor liquor license, beer garden and street closing for June 8<sup>th</sup> event
  - k. Approve Twisted Corn outdoor liquor license, beer garden and street closing for BACoon Ride on June 15<sup>th</sup>
  - l. Accept Scott Bailey's resignation from Planning and Zoning effective April 1, 2019, term expires October 1, 2020
  - m. Approve invoices for payment (review committee Kluss and Coon)
5. Approve hiring assistant Pool manager at \$12.00/hr. while acting as asst. manager – Anna Pion; 4<sup>th</sup> year lifeguard at \$8.75/hr – Anna Pion
6. Public Communications and Concerns [Anyone wanting to speak about a matter not on the Agenda should raise your hand, and the Mayor will acknowledge you. Please stand, state your name, address and topic. You will have two minutes to address the Mayor and Council.]
7. Bob King - Healthy Hometown Initiative report
8. Bob King - AARP grant update, and possible action to authorize expenditure of funds in connection with 8<sup>th</sup> Street connection to Trail
9. Bob King - discussion and possible action on purchasing tennis court backboards in an amount not to exceed \$9,000. This amount is included in the current budget
10. Public Works Report
  - a. Action to approve purchase of 2019 International Plow Truck and accessories in an amount not to exceed \$192,000 with the payment due in FY2020
11. Water Treatment Plant Backwash Improvements Project
  - a. Engineer's Report
  - b. Approve Partial Payment Estimate No. 1 – Thorpe Water Development - \$65,135.56
12. Wastewater Treatment Plant Improvements – Engineer's Report
13. Hatton Avenue Stormwater Project – Engineer's Report

14. Sidewalks on west side of Fair View Drive, south of Linden Street – discussion and possible action
15. Engineer's Report – other matters
  - a. SW Stormwater seeding, plantings and finishing
16. Action to approve resolution 2019-8 – designating the former Hoover Lumberyard property as city park space and naming it Heritage Park
17. Action to approve Letter of Support for the application of re-designation of the Raccoon River Valley Trail (RRVT) as an Iowa Great Place
18. Discussion and possible action on relocation of Veteran's Memorial
19. Action to allow review committee to approve Wells Fargo credit card statements when received and to allow Clerk's office to pay statements, once approved by the review committee
20. Clerk update – City website and online payments
21. Council reports
22. Mayor's report
23. Adjournment

Cindy Riesselman, City Clerk

#### Claims

A King's Throne, Llc	April Serv	\$225.00
Access Systems Leasing	April Serv	\$258.27
Acco Unlimited Corp	Supplies	\$302.50
Ventilation Services Of	April Serv	\$7,500.00
Agsource Cooperative Svcs	Tests	\$548.50
Arnold Auto Supply	Supplies	\$317.86
Baker & Taylor Co.	Books	\$464.00
Mmit Business Solutions Group	March Serv	\$99.93
Bay Bridge Administrators	Insurance	\$100.42
Brown, Fagen & Rouse	April Serv	\$2,250.00
Centurylink	April Serv	\$531.61
Cintas Corporation #762	March Serv	\$124.88
Cj Cooper & Associates	Drug Testing	\$35.00
Core & Main	Repairs	\$13.00
Dallas County Treasurer	April Serv	\$16,970.48
Scott Deaver	Park Signs	\$2,950.00
Delta Dental	Insurance	\$30.20
Delta Dental	Insurance	\$473.84
Digital Stew Services	April Serv	\$191.49
Erica Dumbauld	Reimburse	\$15.50
Earlmay Nursery & Garden	Supplies	\$87.92
Eftps	Taxes	\$3,056.04
Elite Electric & Utility	Repairs	\$40.66
Emergency Services Marketing	Annual Serv	\$735.00
Gatehouse Media Iowa Holdings	Feb Serv	\$577.24
Gis Benefits	Insurance	\$39.88
Gis Benefits	Insurance	\$28.52
Grimes Asphalt and Paving Corp	Supplies	\$652.62
Heartland Co-Op	March Serv	\$1,015.43

Hotsy Cleaning Systems	Supplies	\$470.00
Ipers	Ipers	\$4,553.48
Iron Mountain	March Serv	\$52.79
Karen's Quality Cleaning	March Serv	\$475.00
Kempker's True Value	Repairs	\$2.49
Leaf	April Serv	\$102.08
Ed Leedom	March Serv	\$415.34
Logan Contractors Supply Inc	Repairs	\$58.82
Mccalley Technical Svc, Llc	Repairs	\$710.00
Micromarking Llc	Books	\$183.47
Midamerican Energy	Feb Serv	\$1,252.05
Midamerican Energy	March Serv	\$3,690.90
Moss Bros, Inc	Repairs	\$206.94
Napa Auto Parts	Supplies	\$143.01
Nationwide Retirement Sol	Deferred Comp	\$350.00
Office Depot	Supplies	\$82.58
Praxair Distribution	March Serv	\$28.53
Quill Corporation	Supplies	\$46.22
Cindy Riesselman	Mileage	\$19.72
Greg Simmons	Repairs	\$50.00
Treasurer - State Of Iowa	Taxes	\$890.23
Treasurer - State Of Iowa	Taxes	\$1,714.80
Thorpe Water Development	Backwash Project	\$65,135.56
Usa Blue Book	Supplies	\$460.86
Veenstra & Kimm	March Serv	\$10,211.45
Verizon Wireless	March Serv	\$120.07
Treasurer - State Of Iowa	Taxes	\$1,071.00
Waste Management	March Serv	\$16,666.12
Wellmark Bcbs	Insurance	\$373.04
Wellmark Bcbs	Insurance	\$7,489.25
Wells Fargo	Postage/Books/Supplies	\$370.32
Ziegler Inc	Repairs	\$140.93
Report Total		<u>\$157,172.84</u>

General	\$50,026.45
Rut	\$2,687.45
T&A(Eb)	\$10,353.77
Water	\$73,084.91
Sewer	\$20,921.98
Storm District	<u>\$98.28</u>
Total By Fund	<u>\$157,172.84</u>

Revenues

General Total	\$36,780.47
---------------	-------------

T&A (Pd) Benevolent Total	\$1.23
T&A(Ft) Total	\$6.05
T&A(Sc) Total	\$20.04
Capital Improvement Total	\$79.64
T&A(SI) Total	\$67.52
Rut Total	\$14,293.46
T&A(Eb) Total	\$3,809.79
Emergency Levy Fund Total	\$389.25
Local Option Sales Tax Total	\$23,457.60
Tif Total	\$1,492.24
Burnett Project Total	\$347.34
T&A(Bc) Total	\$174.41
T&A(Burnett Cap Improve) Total	\$225.53
Debt Service Total	\$8,071.35
T&A(B) Total	\$4.64
T&A(Y) Total	\$4.76
Water Total	\$37,157.58
Sewer Total	\$26,876.16
Storm District Total	\$4,851.25
Total Revenue By Fund	\$158,110.31

Mayor Kidd opened a public hearing at 7:00 pm on March 12, 2019 as advertised for the purpose of hearing comments on the authorization of a Loan and Disbursement Agreement and the Issuance of Notes to evidence the obligation of the City thereunder (Not to Exceed \$3,025,000 Sewer Revenue Capital Loan Notes) with the following statement: In 2001 we were issued our NPDES permit by the DNR to operate our wastewater treatment plant, that permit expired in 2006. We had been made aware that when the new permit was issued, we would be mandated to meet stricter guidelines, requiring us to upgrade our facility. The new requirements would impose limits on ammonia nitrogen in the effluent and limits on e-coli bacteria in the effluent. The existing lagoon system, while capable of meeting permit requirements at the time of construction and in 2001, would not be able to meet these two new requirements. In 2013 the council increased the sewer rate in order to start saving money for the upgrades that would be mandatory when we received our new permit from the State of Iowa and the city began researching options. In 2016 we received our new permit requirements and began discussing what design options were available to us. In June 2018 council decided to pursue a SAGR system and work began on the design of the system. The estimated cost of the project is 3.1M. The city has approximately \$500,000 saved to use toward this project, allowing us to bond for less than actual cost of the project. We will be utilizing the State Revolving Fund with a 3% interest rate. The Mayor asked for oral comments-Julie Becker had questions. She was made aware all funds are restricted to be used only for this project. This amount is a not to exceed, we use funds necessary for the project. The city did not receive any written comments. Mayor Kidd declared the hearing closed at 7:10 pm.

Mayor Kidd opened a public hearing at 7:10 pm on March 12, 2019 as advertised for the purpose of hearing comments on proposed Fiscal Year 2019-2020 City of Dallas Center Budget. He gave some of the budget highlights. At 7:14 pm he asked for written comments, there were none. The Mayor asked for oral comments-Bob Haxton gave his comments and concerns regarding the budget. Julie Becker gave her comments and concerns regarding the budget. Kluss arrived at 7:21 pm. Bob King gave his comments regarding the budget. Mayor Kidd declared the hearing closed at 7:30 pm.

The Dallas Center City Council met in regular session March 12, 2019 at 7:30 pm. Mayor Kidd called the meeting to order and led the pledge of allegiance. Council members present included David Bagby, Ryan Coon, Danny Beyer and Ryan Kluss. Curtis Pion was not present.

Motion by Beyer, 2<sup>nd</sup> by Coon to approve agenda. Motion passed 4-0.

Motion by Kluss, 2<sup>nd</sup> by Bagby to approve consent agenda [approve minutes of February 12<sup>th</sup> regular meeting and February 18<sup>th</sup> special meeting; February Treasurer's Report, Cash Report, Function Report; February Law Enforcement, Fire/Rescue, Compliance and Water Reports; approve Mayor's appointment of Susan Collins to fill vacancy on the Parks and Recreation Board, term expires December 31, 2019; approve hiring Mike Buckalew as a public works assistant at \$11.75/hr approximately 20-25 hours per week effective April 1<sup>st</sup>, pending background check; approve hiring Gary Reutter and James McNeill as summer public works assistants at \$11.00/hr approximately 15 hours/week effective April 1<sup>st</sup> pending background checks; approve invoices for payment (review committee Bagby and Beyer)]. Motion passed 4-0.

#### Public Communications and Concerns-

Bob Haxon stated his concerns regarding conflict of interest.

Julie Becker-stated her concerns on city motto, conflict of interest, gave comments on park board item.

Bob King-informed council of an AARP Community Challenge Grant

City Attorney Ralph Brown made a statement responding to the accusation of conflict of interest. He made it clear per Iowa Code Section 362.5 there is absolutely no conflict of interest in regard to the library addition.

Council member Beyer gave the following remarks regarding accusations by citizens: he presented facts

regarding tax abatements and the differences between our and Adel's; he explained that valuations are increasing due to more houses and more growth; he stated that we are not deficit spending but spending money that has been saved rather than getting a loan for large purchases such as the plow truck, he reiterated that there is no conflict of interest regarding the library project; he explained that formal pay rates for the employees are set in June and that we are on a high deductible health insurance plan to try and keep costs down. He also explained that we don't know what insurance rates will be a year out so we budget accordingly; he stated personal attacks on the city clerk by certain citizens needs to stop and clarified that the clerk's wages as published for calendar 2018 were \$60,528; he compared the clerk's wages to school and other city's wages; he stated that many cities have a city administrator, a clerk, and a finance officer and that our clerk does the work of all those positions; lastly, he explained that it doesn't make sense to budget according to the inflation rate when the growth within our city is more than the inflation rate.

Mary Werch, Park and Recreation Board – discussed designating the trailhead and former lumberyard area as a city park. Attorney Brown stated the council would need to pass a resolution and name the park. Council directed Attorney Brown to draft a resolution for next month.

Motion by Kluss, 2<sup>nd</sup> by Beyer to receive the Auditor of State's Report on Applying Agreed-Upon Procedures for the period July 1, 2017, through June 30, 2018. Motion passed 4-0.

Slaughter gave the public works report-thanked council for all of their work; 8 snow events and hauled the snow; cleaned intakes; received and used the last load of salt; made plow repairs-axle shaft, hydraulic tank; repaired snow blower; pothole filling has started; water main break repair; DNR license renewals and CPO license update completed.

Water Treatment Plant Backwash Improvements Project –Engineer Veenstra made council aware that the DNR will grant the city's permit for work to be completed on the south side. Work should start in the next week or two.

#### **Not to Exceed \$3,025,00 Sewer Revenue Capital Loan Notes (SRF)**

Veenstra explained the process for the project and discussed the precursor actions, getting loan closed, bids will be received this summer, he stated there are new contractors in the market and they've been seeing prices coming in lower causing a favorable market.

Motion by Kluss, 2<sup>nd</sup> by Beyer to approve Resolution 2019-7 – instituting proceedings to take additional action for the authorization of a Loan and Disbursement Agreement and the Issuance of Not to Exceed \$3,025,000 Sewer Revenue Capital Loan Notes. Roll call all ayes, motion passed.

Motion by Coon, 2<sup>nd</sup> by Kluss to approve Resolution 2019-8 – approving Fiscal Year 2019-2020 City of Dallas Center budget. Roll call all ayes, motion passed.

Fire Chief Hofland presented information on the purchase of an I-Pad. Motion by Coon, 2<sup>nd</sup> by Bagby to approve fire department's purchase of an I-Pad and monthly data service. I-Pad cost not to exceed \$1300 and \$600 annually for data service. Motion passed 4-0.

Veenstra gave history on the annexation moratoriums with Waukee and Adel. They will be expiring soon. He explained that moratoriums have a ten-year cap. Adel agreement expires this year and Waukee expires 2021. The Mayor will reach out to Adel and Waukee to discuss possible moratorium extensions. The clerk will schedule an annexation workshop with councilmen Kluss and Beyer in the near future.

Proclamation by Mayor – proclaiming April 2019 as Keep Iowa Beautiful Month

Council reports-Coon-thanked employees for their work on the website  
Beyer would like the relocation of the Veteran's Memorial placed on the April agenda

Mayor's report-Kidd stated he thought the new website looked good.

Meeting adjourned at 8:48 pm.

Cindy Riesselman, City Clerk

Claims		
A King's Throne, Llc	March Serv	\$270.00
Access Systems Leasing	March Lease	\$258.27
Ventilation Services Of	Sewer Maint	\$6,525.00
Agsource Cooperative Svcs	Tests	\$548.50
Arnold Auto Supply	Supplies	\$89.94
Baker & Taylor Co.	Books	\$653.38
Mmit Business Solutions Group	March Lease	\$99.93
Bay Bridge Administrators	Ins	\$100.42
Brenton Arboretum	Trees	\$399.00
Brown, Fagen & Rouse	Retainer	\$2,250.00
Center Point Large Print	Books	\$265.52
Country Gardens Magazine	Subscription	\$21.37
Central Salt, Llc	Salt	\$1,692.50
Centurylink	Feb Serv	\$667.33
Cintas Corporation #762	Feb Serv	\$124.88
Core & Main	Repairs	\$1,202.80
Crossroads Ag, Llc	Supplies	\$112.50
Culligan Water System	Feb Serv	\$46.55
Dallas County Treasurer	March Serv	\$16,970.48
Delta Dental	Insu	\$30.20
Delta Dental	Insu	\$473.84
Demco	Supplies	\$105.80
Digital Stew Services	Feb Serv	\$121.50
Ed M Feld Equip. Co., Inc	Supplies	\$130.00
Eftps	Taxes	\$3,108.02
Eftps	Taxes	\$209.26
Eftps	Taxes	\$3,248.39
Emergency Medical Products	Supplies	\$146.39
Gatehouse Media Iowa Holdings	Publications	\$364.20
Gis Benefits	Ins	\$39.88
Gis Benefits	Ins	\$28.52
Git Insurance	Ins	\$67,511.40
Grimes Asphalt and Paving	Tennis Court	\$56,300.00
Gworks	Training	\$180.00
Heartland Co-Op	Feb Serv	\$2,070.75

Hotsy Cleaning Systems	Repairs	\$310.13
Hsa Cory, Rochelle	Hsa	\$100.00
Hsa Hofland, Joel	Hsa	\$50.00
Hsa Riesselman, Cindy	Hsa	\$100.00
Hsa Scrivner, April	Hsa	\$50.00
Hsa Slaughter, Brian	Hsa	\$183.33
Hsa Steele, Kathy	Hsa	\$100.00
Iamu	Dues	\$680.00
Simmering-Cory/Iowa Cod.	Codification	\$906.00
Iowa Pump Works, Inc.	Repairs	\$292.50
Ipers	Ipers	\$4,585.68
Ipers	Ipers	\$180.51
Iron Mountain	Feb Serv	\$52.79
Karen's Quality Cleaning	Feb Serv	\$475.00
Kidd, Mike	Supplies	\$58.78
Kimball Midwest	Repairs	\$216.00
Leaf	Feb Serv	\$102.08
Ed Leedom	Feb Serv	\$420.05
Logan Contractors Supply Inc	Repairs	\$18.46
Mahon Trucking Llc	March Serv	\$750.00
Mccalley Technical Svc, Llc	Feb Serv	\$1,665.00
Menards	Repairs	\$42.43
Merrit Company	Supplies	\$177.48
Midamerican Energy	Jan/Feb Serv	\$1,251.64
Midamerican Energy	Feb Serv	\$3,729.27
Midwest Breathing Air Llc	Tests	\$186.50
Moss Bros, Inc	Repairs	\$23.41
Napa Auto Parts	Repairs	\$477.96
Nationwide Retirement Sol	Deferred Comp	\$350.00
O'Halloran International, Inc.	Repairs	\$591.27
Office Depot	Supplies	\$104.80
Piper Jaffray & Co	Bond Dissemination	\$750.00
Plumb Supply Company	Repairs	\$260.59
Dallas Center Post Office	Postage	\$1,500.00
Praxair Distribution	Feb Serv	\$30.36
Rhinehart Excavating, Inc	Feb Serv	\$600.00
Cindy Riesselman	Training	\$76.07
Sandry Fire Supply	Supplies	\$624.00
April Scrivner	Mileage	\$21.46
Brian Slaughter	Training	\$10.00
Storey Kenworthy/Matt Parrott	Supplies	\$72.48
Strauss Safe & Lock Co.	3rd Qtr Serv	\$98.85
Usa Blue Book	Supplies	\$454.20
Van Wall Equipment	Repairs	\$1,475.53



Veenstra & Kimm	Feb Serv	\$6,504.55
Verizon Wireless	Feb Serv	\$120.03
Treasurer - State of Iowa	Taxes	\$1,078.00
Treasurer - State of Iowa	Taxes	\$26.00
Waste Management	Feb Serv	\$16,535.40
Wellmark Bcbs	Ins	\$373.04
Wellmark Bcbs	Ins	\$7,489.25
Wells Fargo	Postage/Supplies	\$1,372.62

\*\*\*\* Paid Total \*\*\*\* \$224,070.02

General	\$142,273.71
Rut	\$9,778.60
T&A(Eb)	\$23,833.77
Water	\$17,702.36
Sewer	\$30,481.58
Total By Fund	\$224,070.02

Revenues	
General Total	\$39,966.88
T&A (Pd) Benevolent Total	\$1.16
T&A(Ft) Total	\$5.70
T&A(Sc) Total	\$18.87
Capital Improvement Total	\$74.98
T&A(SI) Total	\$59.92
Rut Total	\$17,548.66
T&A(Eb) Total	\$758.87
Emergency Levy Fund Total	\$75.58
Local Option Sales Tax Total	\$23,404.29
Tif Total	\$212.12
Burnett Project Total	\$25,327.01
T&A(Bc) Total	\$164.20
T&A(Burnett Cap Improve) Total	\$212.33
Debt Service Total	\$5,256.45
T&A(B) Total	\$4.37
T&A(Y) Total	\$4.48
Water Total	\$36,793.59
Sewer Total	\$27,227.72
Storm District Total	\$4,829.36
Total Revenue By Fund	\$181,946.54

**TREASURER'S REPORT**  
**CALENDAR 3/2019, FISCAL 9/2019**

UND	LAST REPORT ON HAND	REVENUES	EXPENSES	CHANGE IN LIABILITY	ENDING BALANCE
01 GENERAL	800,234.22	36,780.47	96,542.52	.00	740,472.17
11 T&A (PD) BENEVOLENT	763.69	1.23	.00	.00	764.92
15 T&A(FT)	253,753.96	6.05	.00	.00	253,760.01
21 T&A(SC)	12,433.97	20.04	.00	.00	12,454.01
29 CAPITAL IMPROVEMENT	314,406.67	79.64	.00	.00	314,486.31
41 T&A(SL)	17,938.12	67.52	.00	.00	18,005.64
10 RUT	266,338.80	14,293.46	11,862.34	.00	268,769.92
12 T&A(EB)	27,304.91	3,809.79	27,297.35	.00	3,817.35
19 EMERGENCY LEVY FUND	1,946.02	389.25	.00	.00	2,335.27
21 LOCAL OPTION SALES TAX	169,705.69	23,457.60	.00	.00	193,163.29
25 TIF	7,244.33	1,492.24	895.58	.00	7,840.99
66 T&A(REC PROGRAM) REV	.00	.00	.00	.00	.00
67 BURNETT PROJECT	640,495.28	347.34	.00	.00	640,842.62
68 T&A(BC)	736,207.84	174.41	.00	.00	736,382.25
69 T&A(BURNETT CAP IMPROVE)	639,921.14	225.53	.00	.00	640,146.67
77 T&A(PD)	.00	.00	.00	.00	.00
80 REC TRAIL	.00	.00	.00	.00	.00
00 DEBT SERVICE	110,735.53	8,071.35	.00	.00	118,806.88
01 T&A(B)	14,878.41	4.64	.00	.00	14,883.05
02 T&A(Y)	12,950.93	4.76	.00	.00	12,955.69
00 WATER	598,595.25	37,157.58	25,177.56	.00	610,575.27
10 SEWER	907,183.65	26,876.16	36,419.72	.00	897,640.09
40 STORM DISTRICT	185,868.54	4,851.25	196.56	.00	190,523.23
Report Total	5,718,906.95	158,110.31	198,391.63	.00	5,678,625.63

**BALANCE SHEET**  
**CALENDAR 3/2019, FISCAL 9/2019**

CCOUNT NUMBER	ACCOUNT TITLE	MTD BALANCE	YTD BALANCE
01-000-1110	CHECKING-GENERAL	29,463.81	35,025.99
11-000-1110	CHECKING-T&A(PD) BENEVOLENT	.00	.00
15-000-1110	CHECKING-T&A(FT)	.00	.00
21-000-1110	CHECKING-T&A(SC)	.00	.00
29-000-1110	CHECKING-DEPR POLICE	.00	.00
29-000-1111	CHECKING-DEPR NON RUT EQUIP	.00	.00
29-000-1112	CHECKING-DEPR PARK	.00	.00
29-000-1113	CHECKING-DEPR SWIM POOL	.00	.00
29-000-1114	CHECKING-DEPR P/W BLDG	.00	.00
41-000-1110	CHECKING-T&A(SL)	.00	.00
10-000-1110	CHECKING-RUT	13,041.41	13,041.41
10-000-1111	CHECKING-DEPR RUT EQUIP	.00	.00
10-000-1112	CHECKING-SIDEWALK PROJ	.00	.00
112-000-1110	CHECKING-T&A(EB)	2,510.34	2,510.34
119-000-1110	CHECKING-EMERG LEVY	.00	.00
121-000-1110	CHECKING-LOST	.00	.00
121-000-1111	CHECKING-LOST PROP TAX RELIEF	.00	.00
121-000-1112	CHECKING-LOST SWIM POOL	.00	.00
125-000-1110	CHECKING-TIF	.00	.00
166-000-1110	CHECKING-T&A(REC PROGRAM)	.00	.00
167-000-1110	CHECKING-T&A(BURNETT REC)	.00	.00
167-000-1111	CHECKING-T&A(BURNETT REC/POOL)	.00	.00
168-000-1110	CHECKING-T&A(BURNETT LIBRARY)	.00	.00
169-000-1110	CHECKING-T&A(BURNETT CAP IMP)	.00	.00
177-000-1110	CHECKING-T&A(PD) FORFEITURE	.00	.00
180-000-1110	CHECKING-REC TRAIL	.00	.00
200-000-1110	CHECKING-DEBT SERVICE	.00	.00
305-000-1110	CHECKING-PLAYGROUND EQUIP	.00	.00
307-000-1110	CHECKING-2012 HWY 44 TURN LANE	.00	.00
501-000-1110	CHECKING-T&A(B)	.00	.00
502-000-1110	CHECKING-T&A(Y)	.00	.00
600-000-1110	CHECKING-WATER	21,047.41	31,028.40
600-000-1111	CHECKING-WATER SINKING	.00	.00
600-000-1112	CHECKING-T&A(M)	.00	.00
600-000-1113	CHECKING-WATER IMPROVEMENT	.00	.00
600-000-1114	CHECKING-WATER RESERVE	.00	.00
610-000-1110	CHECKING-SEWER	16,005.53	25,985.95
610-000-1111	CHECKING-SEWER SINKING	.00	.00
610-000-1112	CHECKING-SEWER RESERVE	.00	.00
610-000-1113	CHECKING-SEWER IMPROVEMENT	.00	.00
740-000-1110	CHECKING-STORM DISTRICT	4,361.12	8,091.60
	CHECKING TOTAL	86,429.62	115,683.69
001-000-1120	PETTY CASH	.00	100.00
	PETTY CASH TOTAL	.00	100.00
001-000-1160	SAVINGS-GENERAL	89,225.86-	295,346.18

**BALANCE SHEET**  
**CALENDAR 3/2019, FISCAL 9/2019**

ACCOUNT NUMBER	ACCOUNT TITLE	MTD BALANCE	YTD BALANCE
11-000-1160	SAVINGS-T&A(PD) BENEVOLENT	1.23	764.92
15-000-1160	SAVINGS-T&A(FT)	6.05	3,760.01
21-000-1160	SAVINGS-T&A(SC)	20.04	12,454.01
29-000-1160	SAVINGS-DEPR POLICE	.00	.00
29-000-1161	SAVINGS-DEPR NON RUT EQUIP	47.56	29,551.84
29-000-1162	SAVINGS-DEPR PARK	13.63	8,472.44
29-000-1163	SAVINGS-DEPR SWIM POOL	14.68	9,123.23
29-000-1164	SAVINGS-DEPR P/W BLDG	.54	333.83
29-000-1165	SAVINGS-DEPR FIRE	3.23	2,004.97
41-000-1160	SAVINGS-T&A(SL)	67.52	18,005.64
10-000-1160	SAVINGS-RUT	10,610.29-	156,547.68
10-000-1161	SAVINGS-DEPR RUT EQUIP	.00	29,180.83
10-000-1162	SAVINGS-SIDEWALK PROJ	.00	.00
12-000-1160	SAVINGS-T&A(EB)	25,997.90-	1,307.01
19-000-1160	SAVINGS-EMERG LEVY	389.25	2,335.27
21-000-1160	SAVINGS-LOST	23,457.60	193,163.29
21-000-1161	SAVINGS-LOST PROP TAX RELIEF	.00	.00
21-000-1162	SAVINGS-LOST SWIM POOL	.00	.00
25-000-1160	SAVINGS-TIF	596.66	7,840.99
66-000-1160	SAVINGS-T&A(REC PROGRAM)	.00	.00
67-000-1160	SAVINGS-T&A(BURNETT REC)	347.34	215,842.62
67-000-1161	SAVINGS-T&A(BURNETT REC/POOL)	.00	.00
68-000-1160	SAVINGS-T&A(BURNETT LIBRARY)	174.41	108,382.25
69-000-1160	SAVINGS-T&A(BURNETT CAP IMP)	225.53	140,146.67
77-000-1160	SAVINGS-T&A(PD)FORFEITURE	.00	.00
80-000-1160	SAVINGS-REC TRAIL	.00	.00
200-000-1160	SAVINGS-DEBT SERV	8,071.35	118,806.88
305-000-1160	SAVINGS-PLAYGROUND EQUIP	.00	.00
307-000-1160	SAVINGS-2012 HWY 44 TURN LANE	.00	.00
501-000-1160	SAVINGS-T&A(B)	4.64	2,883.05
502-000-1160	SAVINGS-T&A(Y)	4.76	2,955.69
600-000-1160	SAVINGS-WATER	13,861.84-	458,817.48
600-000-1161	SAVINGS-WATER SINKING	4,794.45	43,987.83
600-000-1162	SAVINGS-T&A(M)	.00	4,053.88
600-000-1163	SAVINGS-WATER IMPROVEMENT	.00	10,487.68
600-000-1164	SAVINGS-WATER RESERVE	.00	62,200.00
610-000-1160	SAVINGS-SEWER	29,264.42-	430,419.42
610-000-1161	SAVINGS-SEWER SINKING	3,715.33	44,656.13
610-000-1162	SAVINGS-SEWER RESERVE	.00	83,235.93
610-000-1163	SAVINGS-SEWER IMPROVEMENT	.00	13,342.66
740-000-1160	SAVINGS-STORM DISTRICT	293.57	182,431.63
	SAVINGS TOTAL	126,710.94-	2,692,841.94
001-000-1170	CD-GENERAL	.00	410,000.00
001-000-1171	CD-GENERAL	.00	.00
015-000-1170	CD-T&A (FT)	.00	200,000.00
015-000-1171	CD-T&A (FT)	.00	50,000.00
021-000-1170	CD-T&A (SC)	.00	.00
029-000-1170	CD-DEPR POLICE	.00	.00

**BALANCE SHEET**  
**CALENDAR 3/2019, FISCAL 9/2019**

ACCOUNT NUMBER	ACCOUNT TITLE	MTD BALANCE	YTD BALANCE
29-000-1171	CD-DEPR NON RUT EQUIP	.00	40,000.00
29-000-1172	CD-DEPR PARK	.00	.00
29-000-1173	CD-DEPR SWIM POOL	.00	60,000.00
29-000-1174	CD-DEPR P/W BLDG	.00	80,000.00
29-000-1175	CD-DEPR P/W BLDG	.00	20,000.00
29-000-1176	CD-DEPR FIRE	.00	65,000.00
10-000-1170	CD-RUT	.00	.00
10-000-1171	CD-DEPR RUT EQUIP	.00	70,000.00
67-000-1170	CD-BC RECREATION	.00	100,000.00
67-000-1171	CD-T&A(BURNETT REC/POOL)	.00	325,000.00
68-000-1170	CD-BC LIBRARY	.00	628,000.00
69-000-1170	CD-BC CAP IMPROVE	.00	500,000.00
01-000-1170	CD-T&A (B)	.00	12,000.00
02-000-1170	CD-T&A (Y)	.00	10,000.00
00-000-1170	CD-WATER	.00	.00
00-000-1171	CD-WATER	.00	.00
10-000-1170	CD-SEWER	.00	300,000.00
		-----	-----
	CD'S TOTAL	.00	2,870,000.00
		=====	=====
	TOTAL CASH	40,281.32-	5,678,625.63
		=====	=====

**BUDGET REPORT**  
**CALENDAR 3/2019, FISCAL 9/2019**

PCT OF FISCAL YTD 75.0%

CCOUNT UMBER	ACCOUNT TITLE	TOTAL BUDGET	MTD BALANCE	YTD BALANCE	PERCENT EXPENDED
01-110-6010	POLICE-WAGES	118,061.00	9,460.53	85,144.77	72.12
01-110-6181	POLICE-CLOTHING	600.00	50.00	450.00	75.00
01-110-6210	POLICE-DUES,M'SHIPS, SPE	.00	.00	.00	.00
01-110-6230	POLICE-TRAINING	550.00	41.67	375.03	68.19
01-110-6310	POLICE-OFFICE RENTAL/MAI	.00	.00	.00	.00
01-110-6331	POLICE-VEHICLE OPERATION	24,000.00	1,975.33	17,777.97	74.07
01-110-6332	POLICE-VEHICLE/EQUIP REP	.00	.00	.00	.00
01-110-6371	POLICE-UTILITIES	300.00	.00	118.22	39.41
01-110-6373	POLICE-TELEPHONE	800.00	64.00	576.00	72.00
01-110-6419	POLICE-TECHNOLOGY SERVIC	2,820.00	233.33	2,099.97	74.47
01-110-6499	POLICE-RESERVE OFFICERS	.00	.00	.00	.00
01-110-6505	POLICE-PIONEER GRANT	.00	.00	.00	.00
01-110-6506	POLICE-OFFICE SUPPLIES	.00	.00	.00	.00
01-110-6507	POLICE-OPERATING SUPPLIE	2,100.00	173.33	1,559.97	74.28
01-110-6599	POLICE-PUBLIC RELATIONS	.00	.00	.00	.00
11-110-6599	T&A(PD) BENEVOLENT	.00	.00	.00	.00
129-110-6799	DEPR-POLICE EXPENSE	.00	.00	.00	.00
112-110-6110	POLICE-FICA	9,032.00	723.73	6,513.57	72.12
112-110-6130	POLICE-IPERS	11,523.00	936.59	8,429.31	73.15
112-110-6150	POLICE-GROUP INSURANCE	36,765.00	3,061.33	27,551.97	74.94
112-110-6155	CITY SHARE- HSA	.00	.00	.00	.00
112-110-6160	POLICE-WORKER'S COMP	1,938.00	228.31	2,054.79	106.03
112-110-6170	POLICE-UNEMPLOYMENT	161.00	22.33	200.97	124.83
112-110-6181	POLICE-UNIFORM ALLOWANCE	.00	.00	.00	.00
177-110-6505	T&A(PD) FORFEITURES EXPE	.00	.00	.00	.00
	POLICE TOTAL	208,650.00	16,970.48	152,852.54	73.26
301-150-6010	FIRE DEPT-SALARIES	18,000.00	.00	7,200.00	40.00
301-150-6150	FIRE DEPT-GROUP INSURANC	.00	653.40	653.40	.00
301-150-6210	FIRE DEPT-DUES	300.00	.00	.00	.00
301-150-6230	FIRE DEPT-TRAINING	3,000.00	.00	17.50	.58
301-150-6310	FIRE DEPT-BUILDING MAINT	3,000.00	.00	1,564.70	52.16
301-150-6331	FIRE DEPT-VEHICLE OPERAT	3,000.00	.73	867.50	28.92
301-150-6332	FIRE DEPT-VEHICLE MAINT/	11,000.00	.00	2,400.78	21.83
301-150-6373	FIRE DEPT-TELEPHONE	1,600.00	130.88	1,170.59	73.16
301-150-6412	FIRE DEPT-HEALTH/FITNESS	1,000.00	.00	134.65	13.47
301-150-6415	FIRE DEPT-HYDRANT RENT	.00	.00	.00	.00
301-150-6419	FIRE DEPT-TECHNOLOGY SER	1,000.00	187.94	1,571.17	157.12
301-150-6505	FIRE DEPT-PAGERS/REPAIRS	15,000.00	.00	14,032.43	93.55
301-150-6507	FIRE DEPT-OPERATING SUPP	3,000.00	493.25	2,034.65	67.82
301-150-6599	FIRE DEPT-REPAIRS/SUPP N	21,000.00	624.00	5,498.10	26.18
015-150-6505	T&A(FT)-EXPENSES	.00	.00	.00	.00
029-150-6504	DEPR-FD MINOR EQUIPMENT	.00	.00	.00	.00
112-150-6110	FIRE-FICA	1,377.00	.00	550.98	40.01
112-150-6130	FIRE-IPERS	582.00	.00	113.66	19.53
112-150-6155	CITY SHARE- HSA	.00	.00	374.40	.00
112-150-6160	FIRE-WORKER'S COMP	6,000.00	5,800.00	7,141.00	119.02
	FIRE TOTAL	88,859.00	7,890.20	45,325.51	51.01
001-170-6407	BUILDING INSPECTION FEES	70,000.00	782.55	39,201.18	56.00
	BUILDING INSPECTIONS TOT	70,000.00	782.55	39,201.18	56.00
001-190-6499	ANIMAL IMPOUNDMENT	500.00	.00	62.50	12.50
	ANIMAL CONTROL TOTAL	500.00	.00	62.50	12.50

**BUDGET REPORT**  
**CALENDAR 3/2019, FISCAL 9/2019**

PCT OF FISCAL YTD 75.0%

ACCOUNT NUMBER	ACCOUNT TITLE	TOTAL BUDGET	MTD BALANCE	YTD BALANCE	PERCENT EXPENDED
	PUBLIC SAFETY TOTAL	368,009.00	25,643.23	237,441.73	64.52
01-210-6010	STREETS-WAGES	42,253.00	3,309.02	33,516.97	79.32
01-210-6230	STREETS-EDUCATION/TRAINI	700.00	.00	528.50	75.50
01-210-6332	STREETS-VEHICLE MAINT	100.00	.00	.00	.00
01-210-6417	STREETS-2012 REPAIRS	.00	.00	.00	.00
01-210-6499	STREETS-CONTRACT LABOR	1,000.00	.00	213.00	21.30
01-210-6507	STREETS-SUPPLIES R16	.00	.00	.00	.00
01-210-6599	STREETS-MISC SUPPLIES	1,000.00	.00	447.13	44.71
21-210-6417	T&A(SC)-REFUNDS	1,000.00	.00	.00	.00
29-210-6710	DEPR-NON RUT EQUIP	.00	.00	.00	.00
10-210-6331	RUT-VEHICLE OPERATIONS	3,000.00	114.84	1,845.85	61.53
10-210-6407	RUT-ENGINEERING	.00	.00	.00	.00
10-210-6408	RUT-LIABILITY INSURANCE	10,000.00	.00	.00	.00
10-210-6417	RUT-STREET REPAIRS/MAINT	204,450.00	.00	184,441.86	90.21
10-210-6425	RUT-SIDEWALK IMPROVEMENT	2,000.00	.00	268.00	13.40
10-210-6490	RUT-13ST STREET SIDEWALK	.00	.00	.00	.00
10-210-6504	RUT-STREET EQUIP	.00	.00	.00	.00
10-210-6710	RUT-DEPR EQUIP EXPENSES	.00	.00	.00	.00
112-210-6110	STREETS-FICA - STREETS	3,232.00	253.14	2,594.69	80.28
112-210-6130	STREETS-IPERS	3,989.00	310.15	3,127.47	78.40
112-210-6150	STREETS-GROUP INSURANCE	7,069.00	712.50	5,590.28	79.08
112-210-6155	CITY SHARE- HSA	2,387.00	46.00	2,261.93	94.76
112-210-6160	STREETS-WORKER'S COMP	5,000.00	4,200.00	4,599.00	91.98
112-210-6170	STREETS-UNEMPLOYMENT	.00	.00	.00	.00
112-210-6181	STREETS-UNIFORM ALLOWANC	400.00	.00	400.00	100.00
	ROADS, BRIDGES, SIDEWALK	287,580.00	8,945.65	239,834.68	83.40
110-230-6371	RUT-STREET LIGHTS	25,000.00	1,525.48	15,118.76	60.48
110-230-6509	RUT-STREET SIGNS	2,500.00	.00	2,047.10	81.88
	STREET LIGHTING TOTAL	27,500.00	1,525.48	17,165.86	62.42
110-250-6331	RUT-SNOW REM VEHICLE OPE	3,500.00	1,665.54	2,554.76	72.99
110-250-6332	RUT-SNOW REM VEHICLE REP	4,000.00	3,318.15	3,487.73	87.19
110-250-6499	RUT-SNOW REM CONTRACT LA	4,000.00	1,350.00	2,295.00	57.38
110-250-6599	RUT-SNOW REM SUPPLIES	8,500.00	1,805.00	8,257.25	97.14
	SNOW REMOVAL TOTAL	20,000.00	8,138.69	16,594.74	82.97
001-290-6010	GARBAGE-WAGES	13,865.00	1,066.66	10,602.76	76.47
001-290-6411	GARBAGE-COURT CLAIMS	2,195.00	.00	2,195.00	100.00
001-290-6418	GARBAGE-SALES TAX	5,000.00	734.35	3,290.76	65.82
001-290-6499	GARBAGE-FEES	196,330.00	16,535.40	148,284.94	75.53
001-290-6506	GARBAGE-OFFICE SUPPLIES	1,200.00	.00	376.69	31.39
001-290-6508	GARBAGE-POSTAGE	1,500.00	110.00	110.00	7.33
112-290-6110	GARBAGE-FICA	1,061.00	81.60	811.13	76.45
112-290-6130	GARBAGE-IPERS	1,309.00	100.70	1,000.95	76.47
112-290-6150	GARBAGE-GROUP INSURANCE	7,956.00	627.45	5,311.60	66.76
112-290-6155	CITY SHARE- HSA	2,294.00	29.00	1,546.50	67.41
	GARBAGE TOTAL	232,710.00	19,285.16	173,530.33	74.57
001-299-6010	GARAGE-WAGES	26,491.00	2,033.16	20,496.91	77.37
001-299-6310	GARAGE-BUILDING REPAIRS	5,000.00	42.43	5,546.90	110.94
001-299-6331	GARAGE-VEHICLE OPERATION	3,500.00	114.84	2,014.29	57.55
001-299-6332	GARAGE-VEHICLE REPAIRS	4,000.00	.00	4,247.75	106.19

**BUDGET REPORT**  
**CALENDAR 3/2019, FISCAL 9/2019**

PCT OF FISCAL YTD 75.0%

CCOUNT UMBER	ACCOUNT TITLE	TOTAL BUDGET	MTD BALANCE	YTD BALANCE	PERCENT EXPENDED
01-299-6371	GARAGE-UTILITIES	3,000.00	504.12	2,042.80	68.09
01-299-6373	GARAGE-TELEPHONE	.00	.00	.00	.00
01-299-6399	GARAGE-MINOR REPAIRS/MAI	4,000.00	333.54	3,316.19	82.90
01-299-6490	STREET TREES	23,000.00	.00	12,304.78	53.50
01-299-6507	GARAGE-OPERATING SUPPLIE	5,000.00	129.95	2,287.33	45.75
29-299-6799	DEPR-P/W BLDG EXPENSE	.00	.00	.00	.00
12-299-6110	GARAGE-FICA	2,027.00	155.55	1,568.14	77.36
12-299-6130	GARAGE-IPERS	2,501.00	190.57	1,910.03	76.37
12-299-6150	GARAGE-GROUP INSURANCE	4,729.00	447.43	3,524.58	74.53
12-299-6155	CITY SHARE- HSA	1,550.00	29.00	1,305.99	84.26
12-299-6160	GARAGE-WORKER'S COMP	1,500.00	1,300.00	1,555.00	103.67
	OTHER PUBLIC WORKS TOTAL	86,298.00	5,280.59	62,120.69	71.98
	<b>PUBLIC WORKS TOTAL</b>	<b>654,088.00</b>	<b>43,175.57</b>	<b>509,246.30</b>	<b>77.86</b>
101-350-6501	MOSQUITO SPRAYING	6,000.00	.00	4,582.01	76.37
	WATER,AIR,MOSQUITO CONTR	6,000.00	.00	4,582.01	76.37
	<b>HEALTH &amp; SOCIAL SERVICES</b>	<b>6,000.00</b>	<b>.00</b>	<b>4,582.01</b>	<b>76.37</b>
101-410-6010	LIBRARY-WAGES	77,913.00	5,599.04	57,436.28	73.72
101-410-6230	LIBRARY-TRAINING/EDUCATI	250.00	.00	.00	.00
101-410-6310	LIBRARY-BLDG REPAIR/MAIN	5,000.00	244.50	5,629.71	112.59
101-410-6320	LIBRARY-GROUNDS MAINT	500.00	.00	100.99	20.20
101-410-6340	LIBRARY-COMPUTER MAINT	4,000.00	1,680.00	3,500.75	87.52
101-410-6371	LIBRARY-UTILITIES	6,000.00	423.00	4,028.26	67.14
101-410-6373	LIBRARY-TELEPHONE	2,500.00	304.83	1,703.96	68.16
101-410-6390	LIBRARY-DALLAS CO FOUND	.00	.00	.00	.00
101-410-6419	LIBRARY-TECHNOLOGY SERV	8,400.00	102.08	6,167.72	73.43
101-410-6502	LIBRARY-BOOKS	16,000.00	910.68	12,081.02	75.51
101-410-6505	LIBRARY-OFFICE FURNITURE	500.00	.00	.00	.00
101-410-6507	LIBRARY-SUPPLIES/PROG/DU	6,000.00	194.55	4,509.14	75.15
101-410-6508	LIBRARY-POSTAGE	1,800.00	96.10	1,030.71	57.26
101-410-6599	LIBRARY-EQUIPMENT	.00	.00	.00	.00
101-410-6502	T&A(SL)-EXPENSES	5,000.00	.00	1,311.09	26.22
112-410-6110	LIBRARY-FICA	5,960.00	428.33	4,393.88	73.72
112-410-6130	LIBRARY-IPERS	7,355.00	528.55	5,421.94	73.72
112-410-6150	LIBRARY-GROUP INSURANCE	17,835.00	1,541.73	12,877.92	72.21
112-410-6155	CITY SHARE- HSA	6,200.00	100.00	4,700.00	75.81
112-410-6160	LIBRARY-WORKER'S COMP	200.00	185.00	245.00	122.50
168-410-6721	T&A(BURNETT LIBRARY)-EXP	23,000.00	.00	10,673.23	46.41
501-410-6502	T&A BOOKS-EXPENSE	1,000.00	.00	.00	.00
	<b>LIBRARY TOTAL</b>	<b>195,413.00</b>	<b>12,338.39</b>	<b>135,811.60</b>	<b>69.50</b>
001-430-6010	PARKS-WAGES	40,471.00	1,041.60	18,871.91	46.63
001-430-6230	PARKS-EDUCATION/TRAINING	200.00	.00	.00	.00
001-430-6310	PARKS-BLDG MAINT/REPAIR	15,000.00	.00	2,851.95	19.01
001-430-6320	PARKS-GROUND MAINT/REPAI	11,000.00	270.00	6,480.64	58.91
001-430-6331	PARKS-VEHICLE OPERATION	2,000.00	.00	1,233.86	61.69
001-430-6350	PARKS-EQUIP REPAIRS	1,000.00	.00	64.55	6.46



**BUDGET REPORT**  
**CALENDAR 3/2019, FISCAL 9/2019**

PCT OF FISCAL YTD 75.0%

CCOUNT UMBER	ACCOUNT TITLE	TOTAL BUDGET	MTD BALANCE	YTD BALANCE	PERCENT EXPENDED
01-430-6371	PARKS-UTILITIES	2,200.00	128.89	1,561.13	70.96
01-430-6385	PARKS-PRAIRIE MEADOW GRA	35,000.00	.00	35,000.00	100.00
01-430-6390	PARKS-DALLAS COUNTY FOUN	7,500.00	.00	.00	.00
01-430-6399	PARKS-PARK EQUIP/MAINT	30,000.00	.00	21,848.77	72.83
01-430-6450	PARKS-TREE MAINT	5,000.00	.00	.00	.00
01-430-6460	TREES PLEASE GRANT EXPEN	2,000.00	.00	.00	.00
01-430-6461	TREES FOREVER GRANT EXPE	1,500.00	.00	.00	.00
01-430-6495	PARKS-ACTIVITIES	200.00	.00	.00	.00
01-430-6507	PARKS-MISC OPERATING SUP	2,000.00	.00	153.70	7.69
29-430-6720	DEPR-PARK EXPENSES	.00	.00	.00	.00
12-430-6110	PARKS-FICA	3,096.00	79.68	1,443.64	46.63
12-430-6130	PARKS-IPERS	3,428.00	97.80	1,070.87	31.24
12-430-6150	PARKS-GROUP INSURANCE	791.00	119.62	906.12	114.55
12-430-6155	CITY SHARE- HSA	248.00	8.00	505.49	203.83
12-430-6160	PARKS-WORKER'S COMP	675.00	485.00	663.00	98.22
12-430-6181	PARKS-UNIFORM ALLOWANCE	.00	.00	.00	.00
67-430-6320	T&A(BURNETT REC)-PARK IM	30,000.00	.00	4,000.00	13.33
67-430-6910	T&A(BURNETT REC)-TRANSFE	.00	.00	.00	.00
05-430-6505	PLAYGROUND-EXPENSES	.00	.00	.00	.00
	PARKS TOTAL	193,309.00	2,230.59	96,655.63	50.00
01-440-6010	SWIM POOL-WAGES	49,943.00	563.00	40,310.60	80.71
01-440-6230	SWIM POOL-CPO TRAINING	500.00	300.00	300.00	60.00
01-440-6310	SWIM POOL-EQUIP/BLDG REP	10,000.00	.00	1,259.70	12.60
01-440-6350	SWIM POOL-OPER EQUIP REP	1,000.00	.00	.00	.00
01-440-6371	SWIM POOL-UTILITIES	3,500.00	.00	2,534.95	72.43
01-440-6373	SWIM POOL-TELEPHONE	500.00	25.24	353.38	70.68
01-440-6418	SWIM POOL-SALES TAX	2,500.00	107.63	539.46	21.58
01-440-6501	SWIM POOL-CHEM/INSPEC	6,000.00	.00	1,203.91	20.07
01-440-6507	SWIM POOL-OPERATING SUPP	3,000.00	22.95	1,600.18	53.34
29-440-6599	DEPR-POOL DONATION EXPEN	.00	.00	.00	.00
29-440-6710	DEPR-SWIM POOL EXPENSES	.00	.00	.00	.00
112-440-6110	SWIM POOL-FICA	3,821.00	43.08	3,083.86	80.71
112-440-6130	SWIM POOL-IPERS	655.00	52.85	523.12	79.87
112-440-6150	SWIM POOL-GROUP INS	1,846.00	190.84	1,404.11	76.06
112-440-6155	CITY SHARE- HSA	558.00	12.50	526.78	94.41
112-440-6160	SWIM POOL-WORKER'S COMP	2,000.00	1,285.00	1,285.00	64.25
166-440-6599	T&A(REC PROGRAM) EXPENSE	.00	.00	.00	.00
167-440-6801	T&A(BURNETT REC) PRINCIP	.00	.00	.00	.00
180-440-6320	REC TRAIL-EXPENSES	.00	.00	.00	.00
180-440-6380	REC TRAIL-PROJ MAIN ST G	.00	.00	.00	.00
180-440-6407	ENGINEERING	.00	.00	.00	.00
180-440-6499	REC TRAIL-TRAILHEAD ARTW	.00	.00	.00	.00
180-440-6801	REC TRAIL-BURNETT PRINC	.00	.00	.00	.00
180-440-6851	REC TRAIL-BURNETT INT	.00	.00	.00	.00
502-440-6505	T&A YOUTH-EXPENSES	.00	.00	.00	.00
	RECREATION TOTAL	85,823.00	2,603.09	54,925.05	64.00
	CULTURE & RECREATION TOT	474,545.00	17,172.07	287,392.28	60.56
001-520-6210	ECON DEV-DUES	4,500.00	.00	3,246.00	72.13

**BUDGET REPORT**  
**CALENDAR 3/2019, FISCAL 9/2019**

PCT OF FISCAL YTD 75.0%

CCOUNT UMBER	ACCOUNT TITLE	TOTAL BUDGET	MTD BALANCE	YTD BALANCE	PERCENT EXPENDED
01-520-6371	ECON DEV-UTILITIES	350.00	.00	100.94	28.84
01-520-6402	ECON DEV-ADVERTISING/SIG	1,000.00	.00	.00	.00
01-520-6407	ECON DEV-ENGINEERING	.00	.00	935.10	.00
01-520-6413	ECON DEV-PAYMENT OTHER A	6,000.00	.00	4,500.00	75.00
01-520-6470	ECON DEV-COMPLIANCE	10,000.00	428.00	3,891.16	38.91
01-520-6490	ECON DEV-MISC EXPENSE	19,670.00	.00	18,472.58	93.91
01-520-6499	ECON DEV-OTHER PROF SERV	1,500.00	.00	2,000.00	133.33
01-520-6761	ECON DEV-WALNUT ST INTER	.00	.00	.00	.00
25-520-6411	TIF-LEGAL EXPENSES	.00	.00	.00	.00
25-520-6499	TIF-PIONEER REBATE AGREE	20,000.00	.00	.00	.00
25-520-6799	TIF-STREETSCAPE	.00	.00	.00	.00
	ECONOMIC DEVELOPMENT TOT	63,020.00	428.00	33,145.78	52.60
01-540-6371	P&Z-UTILITIES	.00	.00	.00	.00
01-540-6407	P&Z ENGINEERING	.00	.00	5,972.10	.00
01-540-6414	P&Z-PUBLICATIONS	100.00	.00	93.72	93.72
01-540-6490	P&Z-MISC	.00	.00	.00	.00
	PLANNING & ZONING TOTAL	100.00	.00	6,065.82	6,065.82
	COMMUNITY & ECONOMIC DEV	63,120.00	428.00	39,211.60	62.12
01-610-6010	MAYOR/COUNCIL-WAGES	9,600.00	400.00	8,240.00	85.83
01-610-6210	MAYOR/COUNCIL-DUES	1,000.00	.00	1,102.00	110.20
01-610-6414	MAYOR/COUNCIL-PUBLICATIO	6,000.00	941.44	3,212.59	53.54
01-610-6490	MAYOR/COUNCIL-AUDITS/BON	10,000.00	750.00	750.00	7.50
01-610-6599	MAYOR/COUNCIL-MISC EXPEN	6,856.00	980.68	4,800.03	70.01
112-610-6110	MAYOR/COUNCIL-FICA	734.00	30.60	570.84	77.77
112-610-6130	MAYOR/COUNCIL-IPERS	634.00	37.76	596.60	94.10
112-610-6160	MAYOR/COUNCIL-WORKER'S C	.00	.00	.00	.00
	MAYOR/COUNCIL/CITY MGR T	34,824.00	3,140.48	19,272.06	55.34
001-620-6010	CLERK-WAGES	57,194.00	4,360.40	44,205.98	77.29
001-620-6210	CLERK-DUES	150.00	.00	.00	.00
001-620-6230	CLERK-EDUCATION/TRAINING	2,000.00	483.74	1,784.25	89.21
001-620-6350	CLERK-EQUIPMENT REPAIRS	500.00	.00	.00	.00
001-620-6373	CLERK-TELEPHONE/RADIOS	1,600.00	134.29	1,196.70	74.79
001-620-6419	CLERK-TECHNOLOGY SERVICE	12,000.00	339.98	10,330.37	86.09
001-620-6490	CLERK-CONTRACT LABOR	1,000.00	27.00	844.50	84.45
001-620-6505	CLERK-OFFICE EQUIP PURCH	5,500.00	.00	3,430.96	62.38
001-620-6507	CLERK-MISC OPERATING SUP	4,300.00	219.52	2,242.66	52.15
001-620-6508	CLERK-POSTAGE/BOX RENT	1,500.00	.00	1,133.45	75.56
112-620-6110	CLERK-FICA	4,375.00	333.60	3,381.95	77.30
112-620-6130	CLERK-IPERS	5,399.00	411.62	4,173.06	77.29
112-620-6150	CLERK-GROUP INSURANCE	21,225.00	1,741.91	14,803.22	69.74
112-620-6155	CITY SHARE- HSA	6,417.00	103.50	5,946.20	92.66
112-620-6160	CLERK-WORKER'S COMP	250.00	225.00	361.00	144.40
	CLERK/TREASURER/ADM TOTA	123,410.00	8,380.56	93,834.30	76.03
001-640-6405	ATTORNEY-MISC EXP	3,000.00	.00	202.00	6.73
001-640-6411	ATTORNEY-RETAINER	27,000.00	2,250.00	20,250.00	75.00
	LEGAL SERVICES/ATTORNEY	30,000.00	2,250.00	20,452.00	68.17
001-650-6310	MEMORIAL HALL-BLDG MAINT	3,000.00	237.79	2,892.58	96.42
001-650-6320	MEMORIAL HALL-MISC EXPEN	1,300.00	335.56	1,237.41	95.19

**BUDGET REPORT**  
**CALENDAR 3/2019, FISCAL 9/2019**

PCT OF FISCAL YTD 75.0%

CCOUNT UMBER	ACCOUNT TITLE	TOTAL BUDGET	MTD BALANCE	YTD BALANCE	PERCENT EXPENDED
01-650-6371	MEMORIAL HALL-UTILITIES	6,500.00	581.45	4,497.06	69.19
01-650-6399	MEMORIAL HALL-CAPITAL OU	.00	.00	.00	.00
01-650-6409	MEMORIAL HALL-JANITOR SE	4,300.00	355.38	2,998.94	69.74
01-650-6499	MEMORIAL HALL-ELEV MAINT	3,000.00	.00	1,696.22	56.54
	CITY HALL/GENERAL BLDGS	18,100.00	1,510.18	13,322.21	73.60
01-660-6408	GENERAL-LIABILITY INSURA	35,000.00	31,902.00	31,669.00	90.48
	TORT LIABILITY TOTAL	35,000.00	31,902.00	31,669.00	90.48
01-699-6490	MISC UNALLOCATED REIMB	8,000.00	16.79	7,941.04	99.26
	OTHER GENERAL GOVERNMENT	8,000.00	16.79	7,941.04	99.26
	<b>GENERAL GOVERNMENT TOTAL</b>	<b>249,334.00</b>	<b>47,200.01</b>	<b>186,490.61</b>	<b>74.80</b>
07-210-6407	ENGINEERING	.00	.00	.00	.00
07-210-6499	OTHER CONTRACTUAL SERV	.00	.00	.00	.00
00-210-6801	DS PRINC-2005 STREETS	.00	.00	.00	.00
00-210-6802	DS PRINC-TIF FAIRVIEW	.00	.00	.00	.00
00-210-6803	DS PRINC-2011 STREETS	65,000.00	.00	.00	.00
00-210-6851	DS INT-2005 STREETS	.00	.00	.00	.00
00-210-6852	DS INT-TIF FAIRVIEW	.00	.00	.00	.00
00-210-6853	DS INT-2011 STREETS	35,610.00	.00	17,805.00	50.00
00-210-6899	DS BOND REGISTRATION FEE	500.00	.00	250.00	50.00
	ROADS, BRIDGES, SIDEWALK	101,110.00	.00	18,055.00	17.86
05-430-6385	PLAYGROUND-PRAIRE MDWS G	.00	.00	.00	.00
05-430-6390	PLAYGROUND-DALLAS CNTY G	.00	.00	.00	.00
	PARKS TOTAL	.00	.00	.00	.00
00-815-6801	DS PRINC-2001 EDS	.00	.00	.00	.00
00-815-6802	DS PRINC-2001 SRF	17,000.00	.00	.00	.00
00-815-6851	DS INT-2001 EDS	.00	.00	.00	.00
00-815-6852	DS INT-2001 SRF	613.00	.00	306.25	49.96
00-815-6899	DS BOND REGISTRATIONS FE	18.00	.00	.00	.00
	SEWER/SEWAGE DISPOSAL TO	17,631.00	.00	306.25	1.74
00-865-6801	DS PRINC-2016 SW STORM	115,000.00	.00	.00	.00
00-865-6851	DS INT-2016 SW STORM	75,655.00	.00	37,827.50	50.00
00-865-6899	DS BOND REGISTRATION	500.00	.00	250.00	50.00
	<b>STORM DISTRICT TOTAL</b>	<b>191,155.00</b>	<b>.00</b>	<b>38,077.50</b>	<b>19.92</b>
	<b>DEBT SERVICE TOTAL</b>	<b>309,896.00</b>	<b>.00</b>	<b>56,438.75</b>	<b>18.21</b>
00-810-6010	WATER-WAGES	67,080.00	5,309.87	52,923.45	78.90
00-810-6110	WATER-FICA	5,132.00	406.23	4,079.42	79.49
00-810-6130	WATER-IPERS	6,332.00	498.50	4,976.56	78.59
00-810-6150	WATER-GROUP INSURANCE	15,109.00	1,254.19	10,508.89	69.55
00-810-6155	CITY SHARE- HSA	4,402.00	71.50	3,876.90	88.07
00-810-6160	WATER-WORKER'S COMP	2,800.00	1,750.00	2,072.00	74.00
00-810-6181	WATER-UNIFORM ALLOWANCE	400.00	.00	400.00	100.00
00-810-6210	WATER-DUES	1,300.00	680.00	1,485.41	114.26
00-810-6230	WATER-TRAINING	1,500.00	10.00	760.00	50.67
00-810-6310	WATER-EQUIP/REPAIRS/MAIN	25,000.00	1,513.76	16,142.57	64.57
00-810-6320	WATER-WELL MAINTENANCE	15,000.00	.00	19,537.40	130.25

**BUDGET REPORT**  
**CALENDAR 3/2019, FISCAL 9/2019**

PCT OF FISCAL YTD 75.0%

ACCOUNT NUMBER	ACCOUNT TITLE	TOTAL BUDGET	MTD BALANCE	YTD BALANCE	PERCENT EXPENDED
300-810-6331	WATER-VEHICLE OPERATIONS	2,000.00	49.21	1,031.74	51.59
300-810-6332	WATER-VEHICLE REPAIRS	500.00	.00	.00	.00
300-810-6340	WATER-OFFICE EQUIP	.00	.00	.00	.00
300-810-6350	WATER-CAPITAL PROJECTS	200,000.00	.00	380.00	.19
300-810-6371	WATER-UTILITIES	19,000.00	1,108.35	14,892.31	78.38
300-810-6373	WATER-TELEPHONE	1,000.00	72.09	656.56	65.66
300-810-6374	T&A(M)DEPOSIT REFUND	13,000.00	75.42	5,059.54	38.92
300-810-6401	WATER-AUDIT	.00	.00	.00	.00
300-810-6407	WATER-ENGINEERING	5,000.00	218.00	2,694.25	53.89
300-810-6408	WATER-INSURANCE	8,200.00	8,000.00	8,000.00	97.56
300-810-6411	WATER-LEGAL	.00	.00	1,442.73	.00
300-810-6418	WATER-SALES TAX EXPENSE	22,000.00	3,592.01	17,014.64	77.34
300-810-6419	WATER-TECHNOLOGY SERVICE	5,000.00	7.95	1,859.11	37.18
300-810-6499	WATER-TESTS	5,000.00	497.20	4,050.95	81.02
300-810-6501	WATER-SALT/CHEMICALS	33,000.00	.00	8,472.04	25.67
300-810-6506	WATER-OFFICE SUPPLIES	1,500.00	.00	497.29	33.15
300-810-6507	WATER-OPERATING SUPPLIES	3,000.00	.00	161.67	5.39
300-810-6508	WATER-POSTAGE	1,500.00	.00	1,500.00	100.00
300-810-6599	WATER-MISC EXP	2,500.00	63.28	1,750.92	70.04
300-810-6780	WATER-CAPITAL IMPROVEMEN	175,000.00	.00	100.00	.06
300-810-6801	WATER DEBT-PRINC 1996	.00	.00	.00	.00
300-810-6802	WATER DEBT PRINC 1999	.00	.00	.00	.00
300-810-6803	WATER DEBT-PRINC 2008 WT	44,000.00	.00	.00	.00
300-810-6854	WATER DEPT-INT 2008 WTR	16,800.00	.00	8,400.00	50.00
300-810-6851	WATER DEBT-INT 1996	.00	.00	.00	.00
300-810-6852	WATER DEBT-INT 1999	.00	.00	.00	.00
300-810-6899	WATER-BOND REGISTRATION	1,400.00	.00	.00	.00
	WATER TOTAL	703,455.00	25,177.56	194,726.35	27.68
310-815-6010	SEWER-WAGES	68,105.00	5,370.25	53,429.94	78.45
310-815-6110	SEWER-FICA	4,757.00	410.73	4,117.32	86.55
310-815-6130	SEWER-IPERS	6,429.00	504.16	5,025.66	78.17
310-815-6150	SEWER-GROUP INSURANCE	13,067.00	1,355.94	10,394.28	79.55
310-815-6155	CITY SHARE- HSA	3,844.00	100.50	4,955.81	128.92
310-815-6160	SEWER-WORKER'S COMP	1,400.00	726.00	862.00	61.57
310-815-6181	SEWER-UNIFORM ALLOWANCE	400.00	.00	400.00	100.00
310-815-6210	SEWER-DUES	350.00	.00	.00	.00
310-815-6230	SEWER-EDUCATION/TRAINING	1,000.00	.00	60.00	6.00
310-815-6310	SEWER-BLDG REPAIR/MAINT	500.00	.00	186.49	37.30
310-815-6320	SEWER-GROUND REPAIR/MAIN	2,500.00	.00	.00	.00
310-815-6331	SEWER-VEHICLE OPERATIONS	1,600.00	49.21	863.27	53.95
310-815-6332	SEWER-VEHICLE REPAIRS	300.00	.00	.00	.00
310-815-6340	SEWER-OFFICE EQUIP	.00	.00	.00	.00
310-815-6350	SEWER-OPERATION/MAINT	16,000.00	6,525.00	10,932.57	68.33
310-815-6371	SEWER-UTILITIES	9,000.00	710.03	7,077.10	78.63
310-815-6373	SEWER-TELEPHONE	.00	.00	.00	.00
310-815-6374	SEWER DEPOSITS	500.00	.00	1,213.26	242.65
310-815-6407	SEWER-ENGINEERING	135,000.00	5,504.00	8,342.00	6.18
310-815-6408	SEWER-INSURANCE	12,000.00	11,000.00	11,000.00	91.67
310-815-6411	SEWER-LEGAL	500.00	.00	.00	.00
310-815-6418	SEWER-SALES TAX EXPENSE	4,200.00	642.68	3,146.65	74.92
310-815-6419	SEWER-TECHNOLOGY SERVICE	5,500.00	7.95	1,683.61	30.61

**BUDGET REPORT**  
**CALENDAR 3/2019, FISCAL 9/2019**

PCT OF FISCAL YTD 75.0%

ACCOUNT NUMBER	ACCOUNT TITLE	TOTAL BUDGET	MTD BALANCE	YTD BALANCE	PERCENT EXPENDED
10-815-6499	SEWER-TESTS	8,000.00	505.50	4,665.65	58.32
10-815-6506	SEWER-OFFICE SUPPLIES	2,000.00	.00	497.28	24.86
10-815-6507	SEWER-SUPPLIES	1,000.00	.00	180.32	18.03
10-815-6508	SEWER-POSTAGE	1,500.00	1,500.00	1,500.00	100.00
10-815-6599	SEWER-ADMIN EXPENSES	350.00	38.77	185.57	53.02
10-815-6780	SEWER-CAPITAL OUTLAY PRO	150,000.00	.00	.00	.00
10-815-6801	SEWER DEBT-PRINC-2001 ED	43,000.00	.00	.00	.00
10-815-6802	SEWER DEBT-PRINC 1999	.00	.00	.00	.00
10-815-6803	SEWER DEBT-PRINC WASS	.00	.00	.00	.00
10-815-6851	SEWER DEBT-INT 2001 EDS	1,540.00	.00	770.00	50.00
10-815-6853	SEWER DEBT-INT WASS	.00	.00	.00	.00
10-815-6852	SEWER DEBT-INT-1999	.00	.00	.00	.00
10-815-6899	SEWER DEBT-REGISTRAR FEE	44.00	.00	.00	.00
	SEWER/SEWAGE DISPOSAL TO	494,386.00	34,950.72	131,488.78	26.60
40-865-6379	STORM DISTRICT-MAINT/REP	40,000.00	.00	27,688.72	69.22
40-865-6407	STORM DISTRICT-ENGINEER	5,000.00	.00	516.00	10.32
40-865-6411	STORM DISTRICT-LEGAL	.00	.00	.00	.00
40-865-6418	STORM DISTRICT-SALES TAX	1,000.00	196.56	876.40	87.64
40-865-6419	STORM DISTRICT-TECH SERV	.00	.00	.00	.00
40-865-6765	STORM DISTRICT-CAPITAL P	17,500.00	.00	17,500.00	100.00
40-865-6801	PRINCIPAL PAYMENTS	.00	.00	.00	.00
40-865-6851	INTEREST PAYMENTS	.00	.00	.00	.00
40-865-6899	BOND REGISTRATION FEES	.00	.00	.00	.00
	STORM DISTRICT TOTAL	63,500.00	196.56	46,581.12	73.36
	ENTERPRISE FUNDS TOTAL	1,261,341.00	60,324.84	372,796.25	29.56
01-910-6910	GENERAL-TRANSFERS OUT	98,198.00	.00	98,198.00	100.00
29-910-6910	DEPR-TRANSFER OUT	25,000.00	.00	25,000.00	100.00
10-910-6910	RUT-TRANSFERS OUT	25,000.00	2,083.33	18,749.97	75.00
12-910-6910	T&A(EB)-TRANSFER OUT	.00	.00	.00	.00
19-910-6910	EMERGENCY FUND-TRANSFER	22,197.00	.00	10,219.51	46.04
21-910-6910	LOST-TRANSFER OUT	65,635.00	.00	.00	.00
25-910-6910	TIF-TRANSFER OUT	52,971.00	895.58	47,770.43	90.18
67-910-6910	T&A(BURNETT REC)-TRANSFE	.00	.00	.00	.00
69-910-6910	T&A(BURNETT CAP IMP TRAN	.00	.00	.00	.00
80-910-6910	REC TRAIL-TRANSFER OUT	.00	.00	.00	.00
07-910-6911	TRANSFER OUT - TIF	.00	.00	.00	.00
00-910-6910	WATER-TRANSFERS OUT	6,000.00	.00	6,000.00	100.00
10-910-6910	SEWER-TRANSFERS OUT	23,631.00	1,469.00	19,221.00	81.34
40-910-6910	STORM DISTRICT-TRANSFER	.00	.00	.00	.00
	TRANSFERS TOTAL	318,632.00	4,447.91	225,158.91	70.66
	TRANSFER OUT TOTAL	318,632.00	4,447.91	225,158.91	70.66

**BUDGET REPORT**  
**CALENDAR 3/2019, FISCAL 9/2019**

**PCT OF FISCAL YTD 75.0%**

<b>ACCOUNT NUMBER</b>	<b>ACCOUNT TITLE</b>	<b>TOTAL BUDGET</b>	<b>MTD BALANCE</b>	<b>YTD BALANCE</b>	<b>PERCENT EXPENDED</b>
	TOTAL EXPENSES BY FUNCTI	3,704,965.00	198,391.63	1,918,758.44	51.79

## FIRE & EMS REPORT

March 2019

Total calls : ~~24~~ 25

<sup>4</sup>  
**FIRE 4 total**

1 Alarm call

1 MVC/Water rescue mutual aid with minburn

1 COQ Grimes

1 MVC in town

**EMS 21 Total**

21 calls for service (18 City/ 3 Rural)

# Monthly Water Report

Date	Mar-19														
<b>Water Plant</b>															
Total Gal.>	5,068,500	Max	223,200	Min	114,800	Avg	163,500	Gpm	259						
Total Hrs.>	327.1	Max	13.6	Min	7.6	Avg	10.5								
Last Month.>	4,043,500	Max	238,100	Min	95,400	Avg	144,400	Gpm	257						
Last Year.>	4,126,800	Max	159,600	Min	102,600	Avg	133,100	Gpm	265						
Lbs.of Chlorine	545	Lbs of Fluoride	27	Gallons of salt brine	2,750										
Chlorine.Mg/l	0.73	Fluoride.Mg/l	0.6	Hardness. Mg/l	103	Iron. Mg/l	0.01	Nitrate.Mg/l							
Well															
<b>Date</b>	3/27/2019														
	S	R	DD	Gpm	S	R	DD	Gpm	S	R	DD	Gpm	S	R	DD
Well # 7	42	24	18	170											
Well # 8	40	28	12	100											
Well # 9	37	30	7	180											
Well # 10	25	8	17	120											
Test Well															
<b>Water Meters</b>	New Installs				Read In										
	Replace Meter				Read Out										
	Replace Radio Read				Shut off For nonpayment										
	Repair														
Fire Hydrants	New Install				Flush Hyd			Repair Hyd							
Water Plant	3/6/2019 - Backwashed filters 1-2-3 no issues.														
Water Tower	3/25/2019 - 3/28/2019 - Raised tower level to 27 feet for summer level.														
Reservoir															
Dist. System															
Wells	3/27/2019 - Tested wells 7-8-9-10														
Other															





# March Dallas Center Calls



DATE/TIME	INCIDENT	LOCATION
2019-03-01 08:55	MEDICAL ALARM	203 13TH ST, DALLAS CENTER
2019-03-01 09:19	THEFT	1707 VINE ST, DALLAS CENTER
2019-03-01 15:45	MEDICAL/AMBULANCE TRIP	309 HIGHVUE TER, DALLAS CENTER
2019-03-02 12:03	TRAFFIC STOP	400 KELLOGG AVE, DALLAS CENTER
2019-03-02 12:39	TRAFFIC COMPLAINT	601 LINDEN ST, DALLAS CENTER
2019-03-02 14:01	INFORMATION	1502 WALNUT ST, DALLAS CENTER
2019-03-03 01:27	DISTURBANCE	201 PERCIVAL AVE, DALLAS CENTER
2019-03-03 06:02	DISTURBANCE	201 PERCIVAL AVE, DALLAS CENTER
2019-03-03 06:39	DISTURBANCE	201 PERCIVAL AVE, DALLAS CENTER
2019-03-03 08:25	MOTORIST ASSIST	2400 240TH ST, DALLAS CENTER
2019-03-03 15:44	TRAFFIC STOP	SUGAR GROVE AVE / 13TH ST, DALLAS CENTER
2019-03-03 19:26	TRAFFIC STOP	FAIRVIEW DR / ELM CT, DALLAS CENTER
2019-03-03 19:46	TRAFFIC COMPLAINT	13TH ST / MAPLE ST, DALLAS CENTER
2019-03-03 20:13	ALARM	1400 VINE ST, DALLAS CENTER
2019-03-04 07:47	TRAFFIC STOP	1915 SUGAR GROVE AVE, DALLAS CENTER
2019-03-04 12:42	PREMISES CHECK	1101 WALNUT ST, DALLAS CENTER
2019-03-04 18:30	MEDICAL/AMBULANCE TRIP	1506 SYCAMORE ST, DALLAS CENTER
2019-03-04 18:46	INFORMATION	1101 WALNUT ST, DALLAS CENTER
2019-03-05 13:03	911 HANGUP	2500 240 <sup>TH</sup> ST, DALLAS CENTER
2019-03-05 15:42	ANIMAL COMPLAINT	11TH ST / WALNUT ST, DALLAS CENTER
2019-03-06 09:37	TRAFFIC STOP	2393 240TH ST, DALLAS CENTER
2019-03-06 10:50	MEDICAL TRANSPORT	1204 LINDEN ST, DALLAS CENTER
2019-03-06 15:58	TRAFFIC STOP	15TH ST / WALNUT ST, DALLAS CENTER
2019-03-07 04:01	EXTRA PATROL	1101 WALNUT ST, DALLAS CENTER
2019-03-07 16:31	911 HANGUP	SUGAR GROVE AVE/KELLOGG AVE, DALLAS CENTER
2019-03-07 17:55	911 HANGUP	QUINLAN AVE/SUGAR GROVE AVE, DALLAS CENTER
2019-03-07 18:43	911 HANGUP	LAUREL ST/13 <sup>TH</sup> ST, DALLAS CENTER
2019-03-08 19:07	INFORMATION	201 PERCIVAL AVE, DALLAS CENTER
2019-03-08 19:57	911 HANGUP	FAIRVIEW
2019-03-09 19:30	VEHICLE UNLOCK	1202 SUGAR GROVE AVE, DALLAS CENTER
2019-03-10 14:20	MEDICAL/AMBULANCE TRIP	1507 SYCAMORE ST, DALLAS CENTER

2019-03-10 14:45	911 MISDIAL	QUINLAN AVE / 240 <sup>TH</sup> ST, DALLAS CENTER
2019-03-10 15:44	FOLLOW UP INVESTIGATION	1101 WALNUT ST, DALLAS CENTER
2019-03-11 16:40	SPECIAL ASSIGNMENT	1205 13TH ST, DALLAS CENTER
2019-03-11 17:25	TRAFFIC STOP	14TH ST / LAUREL ST, DALLAS CENTER
2019-03-11 19:37	SUSPICIOUS	12 ORCHARD LN, DALLAS CENTER
2019-03-11 20:54	SHOTS FIRED	105 PERCIVAL AVE, DALLAS CENTER
2019-03-12 15:57	JUVENILE PROBLEM	1400 VINE ST, DALLAS CENTER
2019-03-12 21:19	FIRE ALARM	810 SUGAR GROVE AVE, Apt. C, DALLAS CENTER
2019-03-12 21:22	OUTAGE	1502 WALNUT ST, DALLAS CENTER
2019-03-12 23:04	MEDICAL/AMBULANCE TRIP	104 PERCIVAL AVE, DALLAS CENTER
2019-03-13 11:10	INFORMATION	SUGAR GROVE AVE/HATTON AVE, DALLAS CENTER
2019-03-13 16:05	TRAFFIC HAZARD	2600 240TH ST, DALLAS CENTER
2019-03-13 16:20	MEDICAL/AMBULANCE TRIP	104 PERCIVAL AVE, DALLAS CENTER
2019-03-13 17:29	SUSPICIOUS	603 ELM CT, DALLAS CENTER
2019-03-13 20:08	THEFT	606 13TH ST, DALLAS CENTER
2019-03-13 21:49	MOTORIST ASSIST	2600 240TH ST, DALLAS CENTER
2019-03-14 09:08	MVC-PD	1205 13TH ST, DALLAS CENTER
2019-03-14 12:48	MEDICAL ALARM	203 13TH ST, DALLAS CENTER
2019-03-14 20:20	MEDICAL/AMBULANCE TRIP	1701 ASH ST, DALLAS CENTER
2019-03-14 21:02	MEDICAL ALARM	203 13TH ST, DALLAS CENTER
2019-03-14 21:05	TRAFFIC HAZARD	2500 240TH ST, DALLAS CENTER
2019-03-15 02:30	INFORMATION	1202 SUGAR GROVE AVE, DALLAS CENTER
2019-03-15 07:20	TRAFFIC HAZARD	240TH ST / QUINLAN AVE, DALLAS CENTER
2019-03-15 08:09	TRAFFIC STOP	2500 240TH ST, DALLAS CENTER
2019-03-15 08:18	TRAFFIC STOP	1900 SUGAR GROVE AVE, DALLAS CENTER
2019-03-15 11:00	CIVIL DISPUTE	1104 SUGAR GROVE AVE, DALLAS CENTER
2019-03-15 12:47	CIVIL DISPUTE	1104 SUGAR GROVE AVE, DALLAS CENTER
2019-03-15 22	INFORMATION	1405 WALNUT ST, DALLAS CENTER
2019-03-15 23:36	MEDICAL ALARM	1107 SUGAR GROVE AVE, Apt. 3, DALLAS CENTER
2019-03-15 23:56	TRAFFIC STOP	SUGAR GROVE AVE / 14TH ST, DALLAS CENTER
2019-03-16 00:11	TRAFFIC STOP	240TH ST / QUINLAN AVE, DALLAS CENTER
2019-03-16 13:38	CIVIL DISPUTE	1806 LINDEN ST, Apt. 11, DALLAS CENTER
2019-03-16 16:58	ANIMAL COMPLAINT	1202 SUGAR GROVE AVE, DALLAS CENTER
2019-03-16 17:09	TRAFFIC STOP	27000 240TH ST, DALLAS CENTER
2019-03-17 00:48	DISTURBANCE	1711 SUGAR GROVE AVE, DALLAS CENTER
2019-03-17 13:57	WELFARE CHECK	1107 SUGAR GROVE AVE, Apt. 12, DALLAS CENTER
2019-03-18 14:02	RETURN PHONE CALL	1806 LINDEN ST, DALLAS CENTER
2019-03-19 10:39	CIVIL PAPER	2525 240TH ST, DALLAS CENTER
2019-03-19 15:32	TRAFFIC STOP	14TH ST / SUGAR GROVE AVE, DALLAS CENTER
2019-03-19 16:04	INFORMATION	803 VINE ST, DALLAS CENTER
2019-03-19 17:30	TRAFFIC STOP	13TH ST / VINE ST, DALLAS CENTER

2019-03-19 17:59	WELFARE CHECK	605 10TH ST, DALLAS CENTER
2019-03-19 20:57	SUSPICIOUS	1502 CHERRY ST, DALLAS CENTER
2019-03-20 01:40	TRAFFIC STOP	14TH ST / SYCAMORE ST, DALLAS CENTER
2019-03-20 01:51	TRAFFIC STOP	10TH ST / VINE ST, DALLAS CENTER
2019-03-20 03:58	MEDICAL/AMBULANCE TRIP	1107 SUGAR GROVE AVE, Apt. 1, DALLAS CENTER
2019-03-20 12:53	911 HANGUP	2500 240 <sup>TH</sup> ST, DALLAS CENTER
2019-03-20 17:06	WARRANT CHECK	1407 WALNUT ST, Apt. B, DALLAS CENTER
2019-03-20 17:34	MOTORIST ASSIST	2360 240TH ST, DALLAS CENTER
2019-03-20 18:22	TRAFFIC STOP	2400 240TH ST, DALLAS CENTER
2019-03-20 19:32	TRAFFIC STOP	2400 240TH ST, DALLAS CENTER
2019-03-20 19:48	CIVIL DISPUTE	523 SYCAMORE ST, DALLAS CENTER
2019-03-20 22:43	PREMISES CHECK	PERCIVAL AVE / SYCAMORE ST, DALLAS CENTER
2019-03-20 22:49	WELFARE CHECK	605 10TH ST, DALLAS CENTER
2019-03-20 23:45	NOISE COMPLAINT	1006 VINE ST, DALLAS CENTER
2019-03-21 08:25	CIVIL PAPER	2525 240TH ST, DALLAS CENTER
2019-03-21 13:28	ABUSE	1202 SUGAR GROVE AVE, DALLAS CENTER
2019-03-21 15:23	CIVIL DISPUTE	523 SYCAMORE ST, DALLAS CENTER
2019-03-21 19:30	TRAFFIC STOP	N AVE / 230TH ST, DALLAS CENTER
2019-03-21 23:12	EXTRA PATROL	2711 250TH ST, DALLAS CENTER
2019-03-21 23:42	TRAFFIC STOP	13TH ST / SYCAMORE ST, DALLAS CENTER
2019-03-22 10:09	TRAFFIC HAZARD	1400 13TH ST, DALLAS CENTER
2019-03-22 10:51	MEDICAL/AMBULANCE TRIP	1204 LINDEN ST, DALLAS CENTER
2019-03-22 12:38	TRAFFIC STOP	2500 240TH ST, DALLAS CENTER
2019-03-22 16:43	MOTORIST ASSIST	2500 240TH ST, DALLAS CENTER
2019-03-22 23:07	MISSING/RUNAWAY	1711 SUGAR GROVE AVE, DALLAS CENTER
2019-03-23 00:08	WARRANT CHECK	1200 ASH ST, DALLAS CENTER
2019-03-23 00:32	TRAFFIC STOP	SUGAR GROVE AVE / 15TH ST, DALLAS CENTER
2019-03-23 01:23	DISTURBANCE	1711 SUGAR GROVE AVE, DALLAS CENTER
2019-03-23 03:46	SUSPICIOUS	SUGAR GROVE AVE / 13TH ST, DALLAS CENTER
2019-03-23 16:03	SUSPICIOUS	607 HATTON AVE, DALLAS CENTER
2019-03-23 19:29	TRAFFIC STOP	2500 240TH ST, DALLAS CENTER
2019-03-23 23:33	MEDICAL TRANSPORT	1204 LINDEN ST, DALLAS CENTER
2019-03-24 00:57	FOLLOW UP INVESTIGATION	1711 SUGAR GROVE AVE, DALLAS CENTER
2019-03-24 10:20	MOTORIST ASSIST	2400 240TH ST, DALLAS CENTER
2019-03-24 14:16	CIVIL PAPER	2525 240TH ST, DALLAS CENTER
2019-03-24 17:36	INFORMATION	523 SYCAMORE ST, DALLAS CENTER
2019-03-24 20:34	MEDICAL/AMBULANCE TRIP	1005 8TH ST, DALLAS CENTER
2019-03-26 07:54	TRAFFIC STOP	810 SUGAR GROVE AVE, DALLAS CENTER
2019-03-26 13:42	TRAFFIC STOP	100 14TH ST, DALLAS CENTER
2019-03-26 21:10	BURGLARY	1806 LINDEN ST, Apt. 9, DALLAS CENTER
2019-03-26 22:09	PUBLIC ASSIST	1005 8TH ST, DALLAS CENTER

2019-03-26 23:27	SUSPICIOUS	1806 LINDEN ST, Apt. 9, DALLAS CENTER
2019-03-27 10:40	FORGERY/FRAUD	1708 VINE ST, DALLAS CENTER
2019-03-27 13:19	MEDICAL/AMBULANCE TRIP	1107 SUGAR GROVE AVE, Apt. 1, DALLAS CENTER
2019-03-27 15:46	TRAFFIC STOP	2500 240TH ST, DALLAS CENTER
2019-03-27 16:23	MEDICAL TRANSPORT	1006 13TH ST, Apt. 207, DALLAS CENTER
2019-03-27 16:25	MEDICAL TRANSPORT	507 14TH ST, DALLAS CENTER
2019-03-27 21:30	SUSPICIOUS	10TH ST / ASH ST, DALLAS CENTER
2019-03-28 08:00	DISTURBANCE	1202 SUGAR GROVE AVE, DALLAS CENTER
2019-03-28 13:10	MEDICAL TRANSPORT	507 14TH ST, DALLAS CENTER
2019-03-28 15:12	MEDICAL TRANSPORT	1204 LINDEN ST, DALLAS CENTER
2019-03-28 19:12	TRAFFIC STOP	SUGAR GROVE AVE / 12TH ST, DALLAS CENTER
2019-03-28 21:03	TRAFFIC STOP	2400 240TH ST, DALLAS CENTER
2019-03-29 01:11	ALARM	1202 SUGAR GROVE AVE, DALLAS CENTER
2019-03-29 01:28	PREMISES CHECK	12 ORCHARD LN, DALLAS CENTER
2019-03-29 05:15	MEDICAL/AMBULANCE TRIP	305 15TH ST, DALLAS CENTER
2019-03-29 15:58	MEDICAL/AMBULANCE TRIP	1204 13TH ST, DALLAS CENTER
2019-03-29 18:41	TRAFFIC STOP	QUINLAN AVE / 240TH ST, DALLAS CENTER
2019-03-29 23:27	MEDICAL/AMBULANCE TRIP	1204 LINDEN ST, Apt. 315, DALLAS CENTER
2019-03-30 14:40	WELFARE CHECK	13 ORCHARD LN, DALLAS CENTER
2019-03-30 20:03	TRAFFIC STOP	1107 SYCAMORE ST, DALLAS CENTER
2019-03-31 08:40	DISTURBANCE	SUGAR GROVE AVE/HATTON AVE, DALLAS CENTER
2019-03-31 11:10	MEDICAL/AMBULANCE TRIP	1107 SUGAR GROVE AVE, Apt. 3, DALLAS CENTER
2019-03-31 19:34	ALARM	1400 VINE ST, DALLAS CENTER
<b>Grand Total</b>	<b>136</b>	<b>324 Hours Patrol/22 Hours Calls- 344 Total Hours 320 Required</b>

# MARCH DALLAS CENTER 2019 CODE ENFORCEMENT

## REPORT

CASE #	ADDRESS	VIOLATION	DATE OF VIOLATION	REINSPECT DATE	COMMENTS	COMPLIED
		BEGIN 2016				
		BEGIN 2017				
2017-051		Property Maintenance	5/24/2017	7/26/2017 10/11/17 12/6/17 1/26/18 5/2/18 8/8/18 12/20/18	Advisory / Will have financing in October 11/1/17 Certified 1/3/18 FINAL NOTICE-- 1-17-18 New contractor will finish in spring 6/20/18 reminder 11/6/18 REMINDER	
		BEGIN 2018				
2018-035	500 Blk of Kellogg	Junk&Vehicle&Bldg Complaint	4/4/2018	6/30/2018 Junk 12/31/18 Bldg 1/31/19	Advisory//5-8-18 Council gave extensions	
2018-150	1501 Linden	Junk	11/13/2018	12/5/2018	Advisory	
		BEGIN 2019				
2019-007	1507 Sycamore	Vehicle	1/7/2019	1/22/2019	Card	3/5/2019
2019-012	600-15	Junk	2/5/2019	2/12/2019 3/8/19	M/ 2/19/19 Advisory	
2019-014	705 Hattton	Property Maintenance	2/19/2019	6/4/2019	Advisory	
2019-015	400-15	Snow	2/19/2019	2/22/2019	Advisory	3/12/2019
2019-016	1207 Vine	Snow	2/26/2019	3/5/2019	Advisory	3/5/2019

2019-017	1703 Walnut	Snow	2/26/2019	3/5/2019	Advisory	3/12/2019
2019-018	601 Percival	Snow	2/26/2019	3/5/2019	Advisory	3/12/2019
2019-019	1402 Sycamore	Snow	2/26/2019	3/5/2019	Advisory	3/12/2019
2019-020	705 Hatton	Junk	2/26/2019	3/5/2019 3/21/19	M/ 3/5/19 Advisory	3/12/2019
2019-021	1701 walnut	Snow	2/26/2019	3/5/2019	Advisory	3/12/2019
2019-022	1205 Laurel	Junk	3/12/2019	3/19/2019	M	3/26/2019
2019-023	1100 Sycamore	Junk	3/12/2019	3/19/2019	M	3/25/2019
2019-024	1300 Cherry	Junk	3/12/2019	3/19/2019	M	3/20/2019
2019-025	1704 Sycamore	J-R.O.W.	3/20/2019	3/26/2019	M	3/26/2019
2019-026	803 Vine	F.Y.P.	3/20/2019	3/26/2019	M	3/26/2019
2019-027	804 Vine	J-R.O.W.	3/20/2019	3/26/2019	M	3/26/2019
2019-028	205-11	Junk	3/26/2019	4/2/2019	C	
2019-029	1607 Laurel	Junk	3/26/2019	4/2/2019	C	
2019-030	1707 Vine	Junk	3/26/2019	4/2/2019	C	
2019-031	1708 Sycamore	Junk	3/26/2019	4/2/2019	C	
2019-032	400-13	F.Y.P.	3/26/2019	4/2/2019	C	

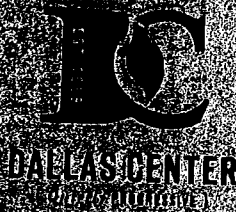

**CITY OF DALLAS CENTER STREET CLOSING PERMIT REQUEST**

This request must be submitted 30 days prior to the event.

Applicant/Organization: DC Celebrations / Seasonal Event Committee

Address: Dallas Center, TX

Phone: [Redacted]

Contact Person: Susan Collins

Address: [Redacted]

Phone: [Redacted]

Date of Event: April 20<sup>th</sup> 2019 Time: 9am to 12pm

Nature of Activity: Outdoor Fitness Games

Streets/Intersections Requested to Be Blocked Off:  
East of Dallas Center Rd. & Walnut St.  
13th Street

[Signature]  
Signature of Applicant

City Council

Copies to: PD  
FD  
RA

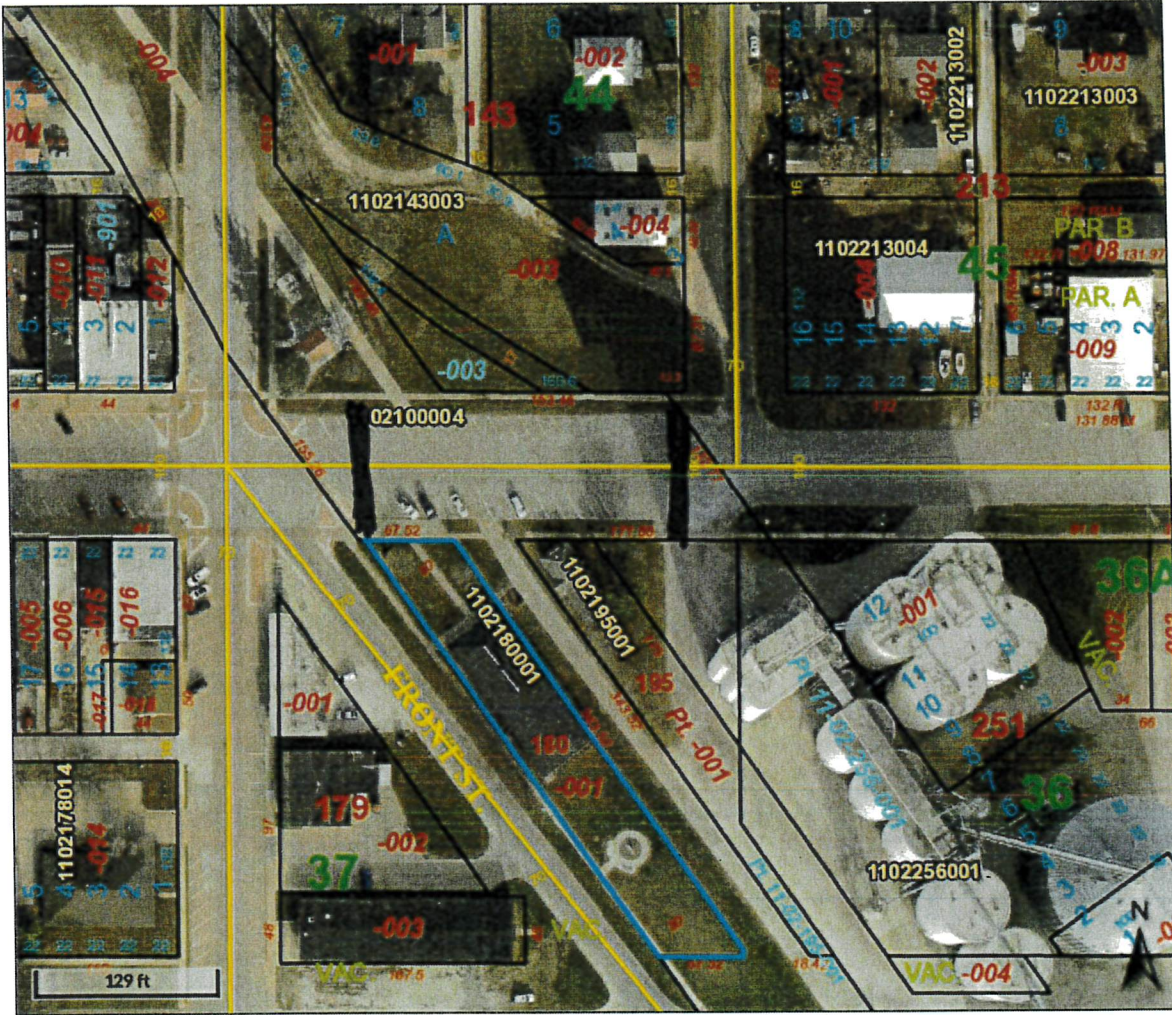

Overview

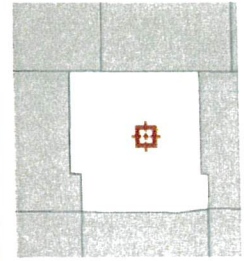

Legend

-  Parcels
-  Road Centerlines
-  City Limits

Parcel ID	1102180001	Alternate ID	n/a	Owner Address	Dallas Center, City Of
Sec/Twp/Rng	2-79-27	Class	C		PO Box 396
Property Address	1308 WALNUT ST DALLAS CENTER	Acres	n/a		Dallas Center, IA 50063-0396
District	DALLAS CENTER CORP URB TIF 3 DCG				
Brief Tax Description	FORMER RR LAND N OF CENTER OF SECTION (STREET)				
	(Note: Not to be used on legal documents)				

Date created: 4/5/2019

Last Data Uploaded: 4/4/2019 9:56:06 PM

Developed by  Schneider  
GEOSPATIAL



**Name of Applicant:** Laughter and Lace LLC

**Name of Business (DBA):** Twisted Corn Tavern

**Address of Premises:** 1405 Walnut Street

**City** Dallas Center                      **County:** Dallas                      **Zip:** 50063

**Business**

**Mailing**                      PO Box 302

**City** Dallas Center                      **State** IA                      **Zip:** 50063

**Contact Person**

**Name** Juanita Slaughter

**Phone**                      **Email**                                                                                    

**Classification** Class C Liquor License (LC) (Commercial)

**Term:** 12 months

**Effective Date:** 04/03/2019

**Expiration Date:** 04/02/2020

**Privileges:**

- Class C Liquor License (LC) (Commercial)
- Outdoor Service

**Status of Business**

**BusinessType:** Limited Liability Company

**Corporate ID Number:** XXXXXXXXXX                      **Federal Employer ID** XXXXXXXXXX

**Ownership**

**Juanita Slaughter**

**First Name:** Juanita                      **Last Name:** Slaughter

**City:** Dallas Center                      **State:** Iowa                      **Zip:** 50063

**Position:** Owner/Manager

**% of Ownership:** 60.00%                      **U.S. Citizen:** Yes

**Randi Boelkes**

**First Name:** Randi                      **Last Name:** Boelkes

**City:** Ankeny                      **State:** Iowa                      **Zip:** 50023

**Position:** Owner/Manager

**% of Ownership:** 40.00%                      **U.S. Citizen:** Yes

**Insurance Company Information**

**Insurance Company:** Illinois Casualty Co

**Policy Effective Date:**

**Policy Expiration**

**Bond Effective**

**Dram Cancel Date:**

**Outdoor Service Effective**

**Outdoor Service Expiration**

**Temp Transfer Effective**

**Temp Transfer Expiration Date:**

14th Street

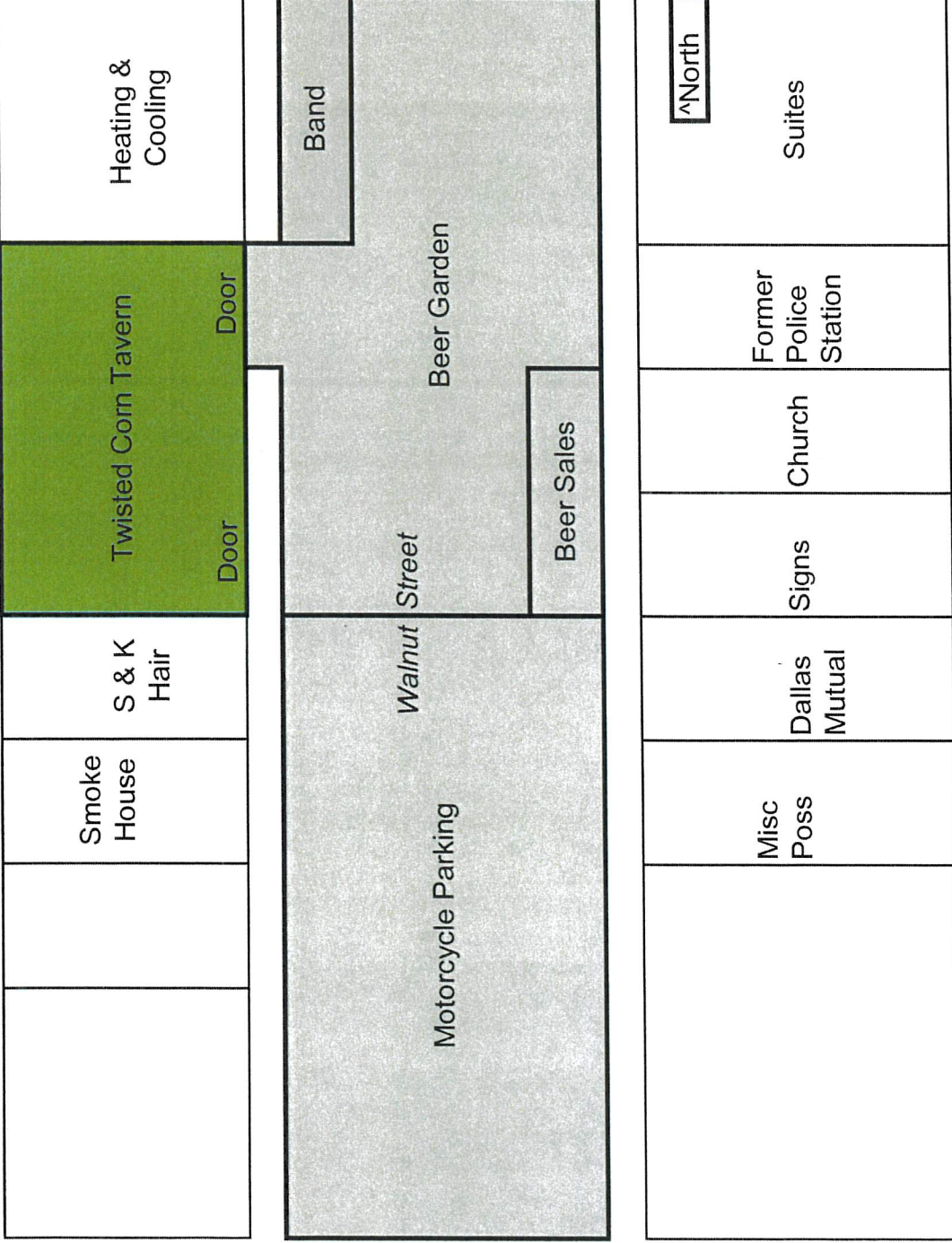

15th Street

Sleeping Angels Fun Run  
10 AM to 2 PM

5/4/19



**DALLAS CENTER**  
( Quietly PROGRESSIVE )

**CITY OF DALLAS CENTER STREET CLOSING PERMIT REQUEST**

**This request must be submitted 30 days prior to the event.**

Applicant/Organization: Twisted Corn Tavern

Address: 1405 Walnut Street

Phone: 992-3868

Contact Person: Randi Boelkes

Address: \_\_\_\_\_

Phone: \_\_\_\_\_

Date of Event: 05/04/2019 Time: 10:00 AM to 2:00 PM

Nature of Activities: Charity Fundraiser/Motorcycle Fun Run

Streets/Intersections Requested to Be Blocked Off:

Walnut Street: between, but not to include, 14th to 15th Streets

See attached sketch

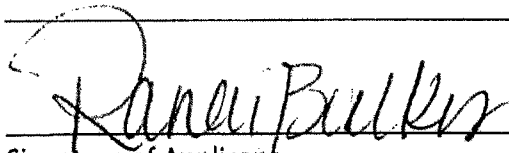

04/03/2019

Signature of Applicant

Date

City Council  Approved  
 Denied

Copies to: PD   
FD   
PW

**Name of Applicant:** Laughter and Lace LLC

**Name of Business (DBA):** Twisted Corn Tavern

**Address of Premises:** 1405 Walnut Street

**City** Dallas Center                      **County:** Dallas                      **Zip:** 50063

**Business**

**Mailing**                      PO Box 302

**City** Dallas Center                      **State** IA                      **Zip:** 50063

**Contact Person**

**Name** Juanita Slaughter

**Phone:**                      **Email**

**Classification** Class C Liquor License (LC) (Commercial)

**Term:** 12 months

**Effective Date:** 04/03/2019

**Expiration Date:** 04/02/2020

**Privileges:**

Class C Liquor License (LC) (Commercial)

Outdoor Service

**Status of Business**

**BusinessType:** Limited Liability Company

**Corporate ID Number:** XXXXXXXXXX                      **Federal Employer ID** XXXXXXXXXX

**Ownership**

**Juanita Slaughter**

**First Name:** Juanita                      **Last Name:** Slaughter

**City:** Dallas Center                      **State:** Iowa                      **Zip:** 50063

**Position:** Owner/Manager

**% of Ownership:** 60.00%                      **U.S. Citizen:** Yes

**Randi Boelkes**

**First Name:** Randi                      **Last Name:** Boelkes

**City:** Ankeny                      **State:** Iowa                      **Zip:** 50023

**Position:** Owner/Manager

**% of Ownership:** 40.00%                      **U.S. Citizen:** Yes

**Insurance Company Information**

**Insurance Company:** Illinois Casualty Co

**Policy Effective Date:**

**Policy Expiration**

**Bond Effective**

**Dram Cancel Date:**

**Outdoor Service Effective**

**Outdoor Service Expiration**

**Temp Transfer Effective**

**Temp Transfer Expiration Date:**

14th Street

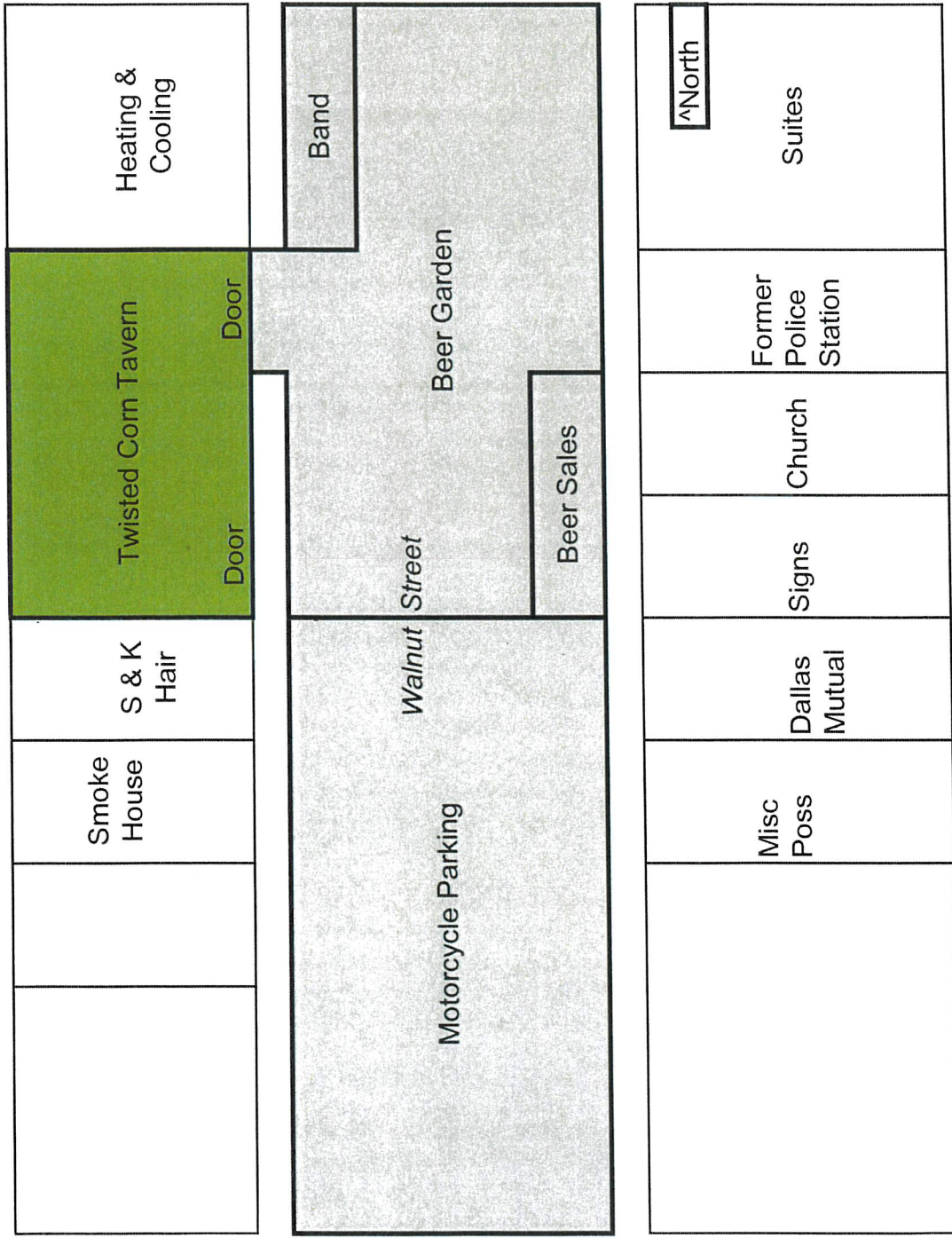

15th Street

 Denotes Closed Street

Puppy Jake Charity Event  
5:30 PM to Midnight

6/8/19



**DALLAS CENTER**  
( Quietly PROGRESSIVE )

**CITY OF DALLAS CENTER STREET CLOSING PERMIT REQUEST**

**This request must be submitted 30 days prior to the event.**

Applicant/Organization: Twisted Corn Tavern

Address: 1405 Walnut Street

Phone: 992-3868

Contact Person: Randi Boelkes

Address: 4

Phone: \_\_\_\_\_

Date of Event: 06/08/2019 Time: 4:00 PM to 12:00 AM

Nature of Activities: Charity Fundraiser/Motorcycle Fun Run

Streets/Intersections Requested to Be Blocked Off:

Walnut Street: between, but not to include, 14th to 15th Streets

See attached sketch

04/03/2019

Signature of Applicant

Date

City Council     Approved  
                          Denied

Copies to:    PD      
                         FD      
                         PW



04/15/19

**Name of Applicant:** Laughter and Lace LLC

**Name of Business (DBA):** Twisted Corn Tavern

**Address of Premises:** 1405 Walnut Street

**City** Dallas Center                      **County:** Dallas                      **Zip:** 50063

**Business**

**Mailing**                      PO Box 302

**City** Dallas Center                      **State** IA                      **Zip:** 50063

**Contact Person**

**Name** Juanita Slaughter

**Phone:** (                      **Email**                      )

**Classification** Class C Liquor License (LC) (Commercial)

**Term:** 12 months

**Effective Date:** 04/03/2019

**Expiration Date:** 04/02/2020

**Privileges:**

Class C Liquor License (LC) (Commercial)

Outdoor Service

**Status of Business**

**BusinessType:** Limited Liability Company

**Corporate ID Number:** XXXXXXXXXX                      **Federal Employer ID** XXXXXXXXXX

**Ownership**

**Juanita Slaughter**

**First Name:** Juanita                      **Last Name:** Slaughter

**City:** Dallas Center                      **State:** Iowa                      **Zip:** 50063

**Position:** Owner/Manager

**% of Ownership:** 60.00%                      **U.S. Citizen:** Yes

**Randi Boelkes**

**First Name:** Randi                      **Last Name:** Boelkes

**City:** Ankeny                      **State:** Iowa                      **Zip:** 50023

**Position:** Owner/Manager

**% of Ownership:** 40.00%                      **U.S. Citizen:** Yes

**Insurance Company Information**

**Insurance Company:** Illinois Casualty Co

**Policy Effective Date:**

**Policy Expiration**

**Bond Effective**

**Dram Cancel Date:**

**Outdoor Service Effective**

**Outdoor Service Expiration**

**Temp Transfer Effective**

**Temp Transfer Expiration Date:**

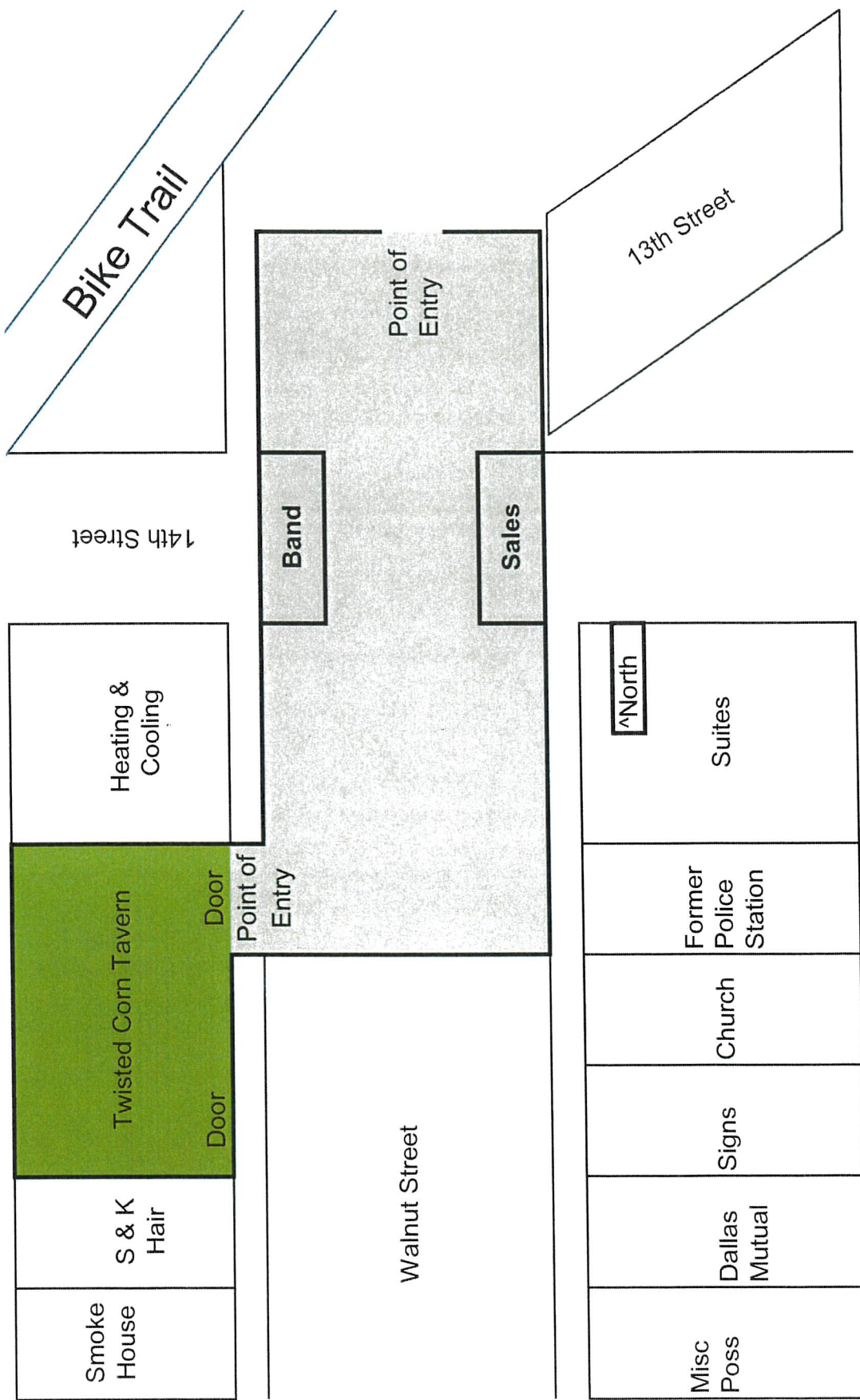

 Denotes Closed Street

BACoon Bicycle Ride  
5 AM to 11 AM

6/15/19



**DALLAS CENTER**  
( *Quietly* PROGRESSIVE )

**CITY OF DALLAS CENTER STREET CLOSING PERMIT REQUEST**

**This request must be submitted 30 days prior to the event.**

Applicant/Organization: Twisted Corn Tavern

Address: 1405 Walnut Street

Phone: 992-3868

Contact Person: Randi Boelkes

Address: 4

Phone: 6

Date of Event: 06/15/2019 Time: 5:00 AM to 11:00 AM

Nature of Activities: Bicycle Ride/BACooN

Streets/Intersections Requested to Be Blocked Off:

Intersection of 15th, 13th, and Walnut Streets and Walnut to the Dining  
entrance of Twisted Corn Tavern.

04/03/2019

Signature of Applicant

Date

City Council  Approved  
 Denied

Copies to: PD   
FD   
PW



The above proposed trail connector from 8<sup>th</sup> Street to the Raccoon River Valley Trail (RRVT) will be approximately 280 feet long and will require approximately 160 square yards of PCC pavement to make a path 5 feet wide. Significant grading and surface restoration will be required to create a trail that is level enough from 8<sup>th</sup> Street to the RRVT to meet ADA standards. Since this path will be located over the top of the existing storm sewer, it will also be necessary to modify the existing storm sewer outlet by turning and angling it to the southeast. The flared end section and rip rap will need to be relocated.

The note below is from Larry Berland, the contact for the Iowa Tennis Coaches Association

Bob,

Sorry for the delay but I have finally finished shoveling snow and ice off our tennis courts! That means that we can begin to practice outdoors.

In answer to your question about what backboard to purchase the following suggestions were given.

If you construct your own from plywood or similar materials, the life span is not great. They begin to lose color very quickly and the wood begins to deteriorate in just a few years.

The backboards recommended were constructed of a hard plastic with the color infused into the material so they do not lose their color. They also are very durable with reports of still looking and functioning well after 15 years plus of use. The types recommended were from Bakko, Rally Master, and Court Master.

Picking a size has to do with your court set-up and expected use. Normal dimensions were 10 foot high by 16 feet wide. If you can afford the added cost, however, 24 feet provides hitting surface for 2 to 3 people at a time. You can purchase curved plastic boards that return the ball as typical of rallying on a court but they do extend an added 30 inches onto the court.

In Decorah, we have a 10x16 foot Rally Master plastic board that they purchased and installed 9 years ago and it still looks and functions like new. It is not a bottom curved model but does have a bit of a curve at the top which stops balls from going out over the top as easily. I like hitting on it but do wish it were a bit wider so that two players could use it at the same time during practice.

I hope this helps with your decision.

Larry

## Rally Master 10 x 32 Back-Sloped Backboard (8°)

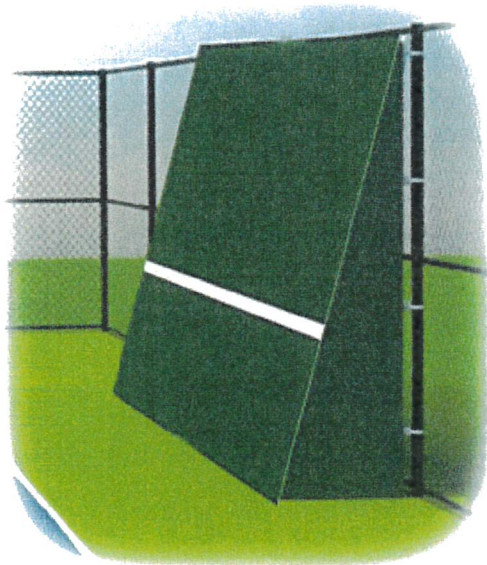

1

 Add to Cart

Add to Wishlist

 Compare

**\$8499.00**



**Price Alerts**

Click to get notified when the price drops



0 Reviews | [Leave Your Review](#)



### Rally Master 10 x 32 Back-Sloped Backboard (8") (Model #rm10x32bs)

An 8-degree back-slope on a backboard provides a lofted ball return that will land further away from the board compared to the flatter, shorter rebound off a flat wall. Some players and coaches prefer the lofted return because it allows more time to prepare for the shot and places the player further from the practice wall. When considering a back-sloped model, remember that the bottom of the backboard will encroach 30" into the court compared with the 4" of intrusion of a flat backboard. Back-sloped models are often placed on the side of court rather than behind the baseline where run back-space is more critical.

Compared to most backboards, the Rally Master 10 x 32 Backboard is more durable and higher-performing. The deep rich color is molded directly into the panel, not painted on a thin outer shell like fiberglass backboards. With this backboard, there is no need to worry about damage due to the solidity of the panels. It is face, chip and peel resistant and it is so versatile, it cannot be punctured like fiberglass from mistreatment or vandalism. In addition to tennis practice, the Rally Master Backboard can be used for other sports such as soccer, basketball and lacrosse.

A 12' wide backboard is sufficient for use by one intermediate or above level player at a time. A 16' wide backboard provides space for two beginners and/or two players of higher levels. The wider the backboard, the more players it can hold and increase your cardiovascular workout level. For private residences, the 16' wide backboard is the most popular while health clubs prefer 20' minimum widths.

With the Rally Master 10 x 32 Backboard, you will also keep your neighbors happy because the highly dense panel construction keeps the noise level to a minimum. Decibel reading tests determined that the rebound sound level of a Rally Master Backboard was indistinguishable from that of a leading fiberglass manufacturer's top-of-the-line model.

#### Do It Tennis is not responsible for the set up of the new backboard.

Installation: Two people can install a 10' x 12' Rally Master Backboard in less than three hours, on a structurally sound, 10' high tennis fence. Each 4' x 10' panel weights 150 lbs. Plan for about one hour or less installation time per 4' x 10' panel. Use additional helpers during the panel attachment procedure if necessary.

#### Shipping company policies state curbside delivery only for residential deliveries.

That means the shipping company will not bring the backboard into your backyard or onto your court. For commercial deliveries, shipping company policies state loading dock delivery or curbside only. You should prepare for receiving your backboard by having people on hand to move the backboard to its intended area of use.

#### Rally Master Warranty:

Rally Master warrants that all their Panels and mounting components shall be free from structural failure for a period of twenty years from the date of shipping. Rally Master's sole obligation under the warranty shall be to repair or replace the defective part(s) only at its sole and absolute option. Rally Master will, at their sole and absolute discretion, determine whether a part repair or part replacement is required. If a part inspection is required prior to our determination, customer will send us the part, pre-paid freight. Customer is responsible for all freight charges on parts repaired or replacement under this warranty. Normal wear and tear, damage through Acts Of God, misuse, improper installation, vandalism, and any claim that is not for structural failure are excluded. Rally Master "Catch Nets" and support poles are not covered by a warranty.

## Rally Master 10 x 32 Backboard

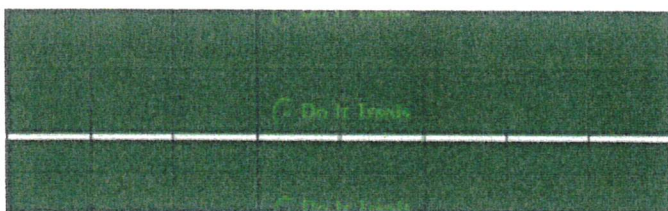

1

 Add to Cart

Add to Wishlist

**\$8499.00**



**Price Alerts**

Click to get notified whe

To: Mayor and Council

April 3, 2019

From: Brian Slaughter, Public Works Director

Re: purchase of dump truck chassis and all accessories

---

Public Works has worked, thru State of Iowa bids, with O'Halloran International Trucks and Hawkeye Truck equipment to put together a snow plow/dump truck that meets public works specs.

O'Halloran International has spec'd a model HV507 SFA single axle truck chassis. Attached are the specifications we have asked for.

Hawkeye Truck Equipment has put together a list of accessory equipment according to our needs. Attached are the specifications we have asked for.

O'Halloran International truck chassis price is \$93,858. Hawkeye Truck Equipment price for all accessories is \$97,556. Total purchase price of \$191,414 for a fully equipped snow plow/dump truck.

Public Works recommends the purchase of truck chassis from O'Halloran International and all accessories from Hawkeye Truck Equipment.





# **HV507 SFA**

Sales Proposal For:

**CITY OF DALLAS CENTER**

Presented By:

**O'HALLORAN INTERNATIONAL**

**Prepared For:**  
CITY OF DALLAS CENTER  
Brian Slaughter  
1502 WALNUT STREET  
DALLAS CENTER, IA 50063-  
(515)992 - 3725

**Presented By:**  
O'HALLORAN INTERNATIONAL  
Bob Kayser  
3311 ADVENTURELAND DRIVE  
ALTOONA IA 50009 -  
(515)967-3300

BRIAN, THE FOLLOWING PRICING IS BASED OFF OF THE LATEST IOWA D.O.T. SNOW REMOVAL EQUIPMENT SOURCEWELL/NJPA CONTRACT DISCOUNT AND AS SUCH IT MUST BE ORDERED BY 12/31/2019. IF THE CITY IS NOT A MEMBER THERE IS NO CHARGE TO SIGN UP TO BE ONE AND I HAVE ALL OF THE INFO IF YOU NEED IT.

THIS CHASSIS IS VERY SIMILAR TO WHAT CLIVE USES HOWEVER I ADDED ALUMINUM OPEN GRATE CAB ENTRY STEPS AND STAINLESS STEEL FUEL TANK STRAPS TO PREVENT RUST, AN EXTERIOR SUNDHADDE OVER THE WINDSHIELD AND SINGLE PEDISTAL AERO STYLE POWER MIRRORS.

\$ 91,558.00	2019 International HV507 Model 4x2 cab and chassis WITH 300 HP L9 Cummins engine
\$ 2,300.00	Estimated price increase for a 2020 Model Year delivered after July 1, 2019
\$ 97,556.00	Snow removal equipment from Hawkeye per Quotation #20973
<hr/>	
\$ 191,414.00	INVOICE PRICE WITH EQUIPMENT FOR DELIVERY AFTER JULY 1, 2019
( 11,000.00)	TRADE ALLOWANCE FOR TRUCK #1 2000 INTERNATIONAL WITH EQUIPMENT
<hr/>	
\$ 180,414.00	TRADE DIFFERENCE FOR DELIVER AFTER JULY 1, 2019

I included a 5" Color dash display monitor instead of 3" Monochromatic text display and if you want the Monochromatic instead you can DEDUCT (369.00) from the price.

Includes 60 Month - 100,000 Miles - 100% engine warranty,

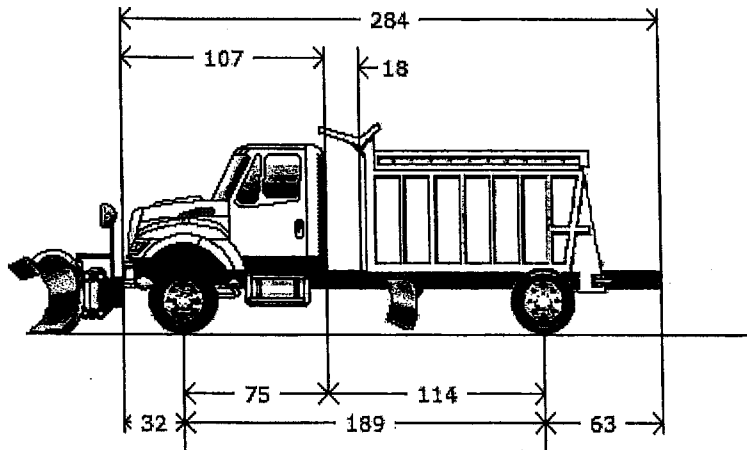

**CITY OF DALLAS CENTER**

**Model Profile  
2020 HV507 SFA (HV507)**

<b>AXLE CONFIG:</b>	4X2
<b>MISSION:</b>	Requested GVWR: 39000. Calc. GVWR: 36220 Calc. Geared Speed: 72.6 MPH
<b>DIMENSION:</b>	Wheelbase: 189.00, CA: 114.00, Axle to Frame: 63.00
<b>ENGINE, DIESEL:</b>	{Cummins L9 300} EPA 2017, 300HP @ 2000 RPM, 860 lb-ft Torque @ 1300 RPM, 2200 RPM Governed Speed, 300 Peak HP (Max)

**TRANSMISSION, AUTOMATIC:** {Allison 3500 RDS} 5th Generation Controls, Wide Ratio, 6-Speed with Double Overdrive, with PTO Provision, Less Retarder, Includes Oil Level Sensor, with 80,000-lb GVW and GCW Max, On/Off Highway

**CLUTCH:** Omit Item (Clutch & Control)

**AXLE, FRONT NON-DRIVING:** {Meritor MFS-14-143A} Wide Track, I-Beam Type, 14,000-lb Capacity

**AXLE, REAR, SINGLE:** {Meritor RS-23-161} Single Reduction, 23,000-lb Capacity, 200 Wheel Ends Gear Ratio: 5.63

**CAB:** Conventional

**TIRE, FRONT:** (2) 11R22.5 Load Range H XDN2 (MICHELIN), 497 rev/mile, 75 MPH, Drive

**TIRE, REAR:** (4) 11R22.5 Load Range H XDN2 (MICHELIN), 497 rev/mile, 75 MPH, Drive

**SUSPENSION, RR, SPRING, SINGLE:** Vari-Rate; 31,000-lb Capacity, Includes 4500-lb Capacity Multileaf Auxiliary

**PAINT:** Cab schematic 100WK  
Location 1: 9219, Winter White (Std)  
Chassis schematic N/A

<u>Code</u>	<u>Description</u>
HV50700	Base Chassis, Model HV507 SFA with 189.00 Wheelbase, 114.00 CA, and 63.00 Axle to Frame.
1570	TOW HOOK, FRONT (2) Frame Mounted
1ANA	AXLE CONFIGURATION {Navistar} 4x2
	<u>Notes</u> : Pricing may change if axle configuration is changed.
1CAJ	FRAME RAILS Heat Treated Alloy Steel (120,000 PSI Yield); 10.866" x 3.622" x 0.433" (276.0mm x 92.0mm x 11.1mm); 456.0" (11582mm) Maximum OAL
1LLA	BUMPER, FRONT Steel, Swept Back
1WDS	FRAME EXTENSION, FRONT Integral; 20" In Front of Grille
1WEV	WHEELBASE RANGE 146" (370cm) Through and Including 195" (495cm)
2ARV	AXLE, FRONT NON-DRIVING {Meritor MFS-14-143A} Wide Track, I-Beam Type, 14,000-lb Capacity
3770	SPRINGS, FRONT AUXILIARY Rubber
3ADD	SUSPENSION, FRONT, SPRING Parabolic Taper Leaf, Shackle Type, 14,000-lb Capacity, with Shock Absorbers
4091	BRAKE SYSTEM, AIR Dual System for Straight Truck Applications
4619	TRAILER CONNECTIONS Four-Wheel, with Hand Control Valve and Tractor Protection Valve, for Straight Truck
4732	DRAIN VALVE {Berg} with Pull Chain, for Air Tank
4AZJ	AIR BRAKE ABS {Bendix AntiLock Brake System} Full Vehicle Wheel Control System (4-Channel) with Automatic Traction Control
4EBD	AIR DRYER {Wabco System Saver 1200} with Heater
4EXP	BRAKE CHAMBERS, FRONT AXLE {Bendix} 20 SqIn
4EXW	BRAKE CHAMBERS, REAR AXLE {Bendix EnduraSure Pro} 30/30 Spring Brake
4JCJ	BRAKES, FRONT, AIR CAM S-Cam; 16.5" x 5.0"; Includes 20 Sq. In. Long Stroke Brake Chambers
4NDB	BRAKES, REAR, AIR CAM S-Cam; 16.5" x 7.0"; Includes 30/30 Sq.In. Long Stroke Brake Chamber and Spring Actuated Parking Brake
4SPA	AIR COMPRESSOR {Cummins} 18.7 CFM Capacity
4VKC	AIR DRYER LOCATION Mounted Inside Left Rail, Back of Cab
4VKJ	AIR TANK LOCATION (2) Mounted Under Battery Box, Outside Left Rail, Back of Cab, Perpendicular to Rail
4WBX	DUST SHIELDS, FRONT BRAKE for Air Brakes
4WDM	DUST SHIELDS, REAR BRAKE for Air Brakes
5710	STEERING COLUMN Tilting and Telescoping
5CAW	STEERING WHEEL 4-Spoke; 18" Dia., Black
5PSA	STEERING GEAR {Sheppard M100} Power
6DAZ	DRIVESHAFT {Dana Spicer} SPL140 in lieu of 1710 Series
7BEV	AFTERTREATMENT COVER Steel, Black

<u>Code</u>	<u>Description</u>
7BKS	EXHAUST SYSTEM Single Horizontal Aftertreatment Device, Frame Mounted Right Side Under Cab; for Single Vertical Tail Pipe, Frame Mounted Right Side Back of Cab
7WAZ	TAIL PIPE (1) Tumbuck Type, Non-Bright, for Single Exhaust
7WBS	MUFFLER/TAIL PIPE GUARD (1) Bright Stainless Steel
7WCM	EXHAUST HEIGHT 8' 10"
7WZY	SWITCH, FOR EXHAUST 2 Position, Lighted & Latching, On/Off Type, Mounted in IP, Inhibits Diesel Particulate Filter Regeneration as Long as Switch is in On Position
8000	ELECTRICAL SYSTEM 12-Volt, Standard Equipment
8518	CIGAR LIGHTER Includes Ash Cup
8541	HORN, ELECTRIC (2) Disc Style
8GGG	ALTERNATOR {Delco Remy 36SI} Brushless, 12 Volt 165 Amp. Capacity, Pad Mount, with Remote Voltage Sensor
8HAB	BODY BUILDER WIRING Back of Standard or Sleeper Cab at Left Frame or Under Extended or Crew Cab at Left Frame; Includes Sealed Connectors for Tail/Amber Turn/Marker/ Backup/ Accessory Power/Ground and Sealed Connector for Stop/Turn
8MSG	BATTERY SYSTEM {Fleetrite} Maintenance-Free, (3) 12-Volt 1980CCA Total
8RMP	RADIO AM/FM/WB/Clock/3.5MM Auxiliary Input
8RMZ	SPEAKERS (2) 6.5" Dual Cone Mounted in Both Doors, (2) 5.25" Dual Cone Mounted in Both B-Pillars
8RPB	RADIO, AUXILIARY CONTROLS Mounted in Steering Wheel, Radio Function Control Switch, Includes Volume Up/Down, Mute, Forward/Back and Bluetooth Answer/Disconnect
8THJ	AUXILIARY HARNESS 3.0' for Auxiliary Front Head Lights and Turn Signals for Front Plow Applications
8TKB	STOP, TURN, TAIL & B/U LIGHTS {Truck Lite} Super 44, with LED Lights for Stop, Turn & Tail Lights and Truck Lite Super 40 for Backup Lights, with Power Module, "International" Termination and Less Junction Box
8TMG	TRAILER CONNECTION SOCKET 7-Way; Mounted at Rear of Frame, Wired for Turn Signals Combined with Stop, Compatible with Trailers That Use Combined Stop, Tail, Turn Lamps
8VUL	BATTERY BOX Steel with Plastic Cover, 18" Wide, 2, 3, or 4 Battery Capacity, Mounted Left Side Back of Cab
8WGL	WINDSHIELD WIPER SPD CONTROL Force Wipers to Slowest Intermittent Speed When Park Brake Set and Wipers Left on for a Predetermined Time
8WPH	CLEARANCE/MARKER LIGHTS (5) {Truck Lite} Amber LED Lights, Flush Mounted on Cab or Sunshade
8WPZ	TEST EXTERIOR LIGHTS Pre-Trip Inspection will Cycle all Exterior Lamps Except Back-up Lights
8WRB	HEADLIGHTS ON W/WIPERS Headlights Will Automatically Turn on if Windshield Wipers are turned on
8WTK	STARTING MOTOR {Delco Remy 38MT Type 300} 12 Volt; less Thermal Over-Crank Protection
8WWJ	INDICATOR, LOW COOLANT LEVEL with Audible Alarm
8WXD	ALARM, PARKING BRAKE Electric Horn Sounds in Repetitive Manner When Vehicle Park Brake is "NOT" Set, with Ignition "OFF" and any Door Opened

<u>Code</u>	<u>Description</u>
8XAH	CIRCUIT BREAKERS Manual-Reset (Main Panel) SAE Type III with Trip Indicators, Replaces All Fuses
8XGT	TURN SIGNALS, FRONT Includes LED Side Turn Lights Mounted on Fender
8XHN	HORN, AIR Black, Single Trumpet, with Lanyard Pull Cord
8XHR	POWER SOURCE, ADDITIONAL Auxiliary Power Output (APO) & USB Port, Located in the Instrument Panel
9AAB	LOGOS EXTERIOR Model Badges
9AAE	LOGOS EXTERIOR, ENGINE Badges
9HBM	GRILLE Stationary, Chrome
9WBC	FRONT END Tilting, Fiberglass, with Three Piece Construction; for WorkStar/HV
10021	CHASSIS COATING Corrosion Resistant E-Coat Primer Coating for Single Frame Rails
10060	PAINT SCHEMATIC, PT-1 Single Color, Design 100
	<u>Includes</u>
	: PAINT SCHEMATIC ID LETTERS "WK"
10761	PAINT TYPE Base Coat/Clear Coat, 1-2 Tone
10AAY	OVER THE AIR PROGRAMMING {Navistar} for Cummins Engines
10JPA	CUSTOMER IDENTITY for National Joint Powers Alliance
10SLV	PROMOTIONAL PACKAGE Government Silver Package
11001	CLUTCH Omit Item (Clutch & Control)
12703	ANTI-FREEZE Red, Extended Life Coolant; To -40 Degrees F/ -40 Degrees C, Freeze Protection
12851	PTO EFFECTS, ENGINE FRONT Less PTO Unit, Includes Adapter Plate on Engine Front Mounted
12EHU	ENGINE, DIESEL {Cummins L9 300} EPA 2017, 300HP @ 2000 RPM, 860 lb-ft Torque @ 1300 RPM, 2200 RPM Governed Speed, 300 Peak HP (Max)
12THT	FAN DRIVE {Horton Drivemaster} Direct Drive Type, Two Speed with Residual Torque Device for Disengaged Fan Speed
12UWZ	RADIATOR Cross Flow, Series System; 1228 SqIn Aluminum Radiator Core with Internal Water to Oil Transmission Cooler and 1167 In Charge Air Cooler
12VAL	AIR CLEANER Dual Element, with Integral Snow Valve and In-Cab Control
12VGN	FEDERAL EMISSIONS {Cummins L9} EPA, OBD and GHG Certified for Calendar Year 2018
12VXV	THROTTLE, HAND CONTROL Engine Speed Control for PTO; Electronic, Mobile, Variable Speed; (Range 2 to 20 MPH) Mounted on Steering Wheel
12VYL	ACCESSORY WIRING, SPECIAL for Road Speed Wire Coiled Under Instrument Panel for Customer Use
12VYP	ENGINE CONTROL, REMOTE MOUNTED No Provision Furnished for Remote Mounted Engine Control
12WZE	EMISSION COMPLIANCE Federal, Does Not Comply with California Clean Air Idle Regulations
13AVL	TRANSMISSION, AUTOMATIC {Allison 3500 RDS} 5th Generation Controls, Wide Ratio, 6-Speed with Double Overdrive, with PTO Provision, Less Retarder, Includes Oil Level Sensor, with 80,000-lb GVW and GCW Max, On/Off Highway

<u>Code</u>	<u>Description</u>
13WDZ	SHIFT CONTROL PARAMETERS Allison S-1 Performance Programming in Primary and Allison Fixed Programming in Secondary
13WET	TRANSMISSION SHIFT CONTROL for Column Mounted Stalk Shifter
13WLP	TRANSMISSION OIL Synthetic; 29 thru 42 Pints
13WUC	ALLISON SPARE INPUT/OUTPUT for Rugged Duty Series (RDS); General Purpose Trucks, Construction
13WYH	TRANSMISSION TCM LOCATION Located Inside Cab
13XAM	PTO LOCATION Dual, Left and Right Side of Transmission
14ASK	AXLE, REAR, SINGLE {Meritor RS-23-161} Single Reduction, 23,000-lb Capacity, 200 Wheel Ends . Gear Ratio: 5.63
14SAL	SUSPENSION, RR, SPRING, SINGLE Vari-Rate; 31,000-lb Capacity, Includes 4500-lb Capacity Multileaf Auxiliary
14WMG	AXLE, REAR, LUBE {EmGard FE-75W-90} Synthetic Oil; 30 thru 39.99 Pints
15924	FUEL TANK STRAPS Bright Finish Stainless Steel
15LLZ	LOCATION FUEL/WATER SEPARATOR Mounted Outside Left Rail, 41" Back of Cab
15LMR	FUEL/WATER SEPARATOR {Racor 400 Series,} with Primer Pump, Includes Water-in-Fuel Sensor
15SGJ	FUEL TANK Top Draw, Non-Polished Aluminum, D-Style, 16" Tank Depth, 50 US Gal (189L), with Quick Connect Outlet, Mounted Left Side, Under Cab
15WDG	DEF TANK 7 U.S. Gal. 26.5L Capacity, Frame Mounted Outside Left Rail, Under Cab
16030	CAB Conventional
16BAM	AIR CONDITIONER with Integral Heater & Defroster
16GDG	GAUGE CLUSTER Premium Level; English with English Speedometer and Tachometer, for Air Brake Chassis, Includes Engine Coolant Temperature, Primary and Secondary Air Pressure, Fuel and DEF Gauges, Oil Pressure Gauge, Includes 5 Inch LCD Color Display
16HGH	GAUGE, OIL TEMP, AUTO TRANS for Allison Transmission
16HKT	IP CLUSTER DISPLAY On Board Diagnostics Display of Fault Codes in Gauge Cluster
16JNT	SEAT, DRIVER {National 2000} Air Suspension, High Back with Integral Headrest, Vinyl, Isolator, 1 Chamber Lumbar, with 2 Position Front Cushion Adjust, -3 to +14 Degree Angle Back Adjust
16SJX	MIRROR, CONVEX, HOOD MOUNTED (2) {Lang Mekra} Bright, Heated, Left and Right Sides 7.44" Sq
16SMN	SEAT, PASSENGER {National} Non Suspension, High Back, Fixed Back, Integral Headrest, Vinyl
16SNV	MIRRORS (2) Aero; Pedestal, Power Adjust, Heated Heads, Turn Signals, Bright Finish Heads, Black Arms, 6.3" x 13.82" Flat Glass, 6.38" x 6.18" Convex Glass Both Sides
16VKB	CAB INTERIOR TRIM Classic, for Day Cab
	<u>Includes</u>
	: CONSOLE, OVERHEAD Molded Plastic with Dual Storage Pockets, Retainer Nets and CB Radio Pocket; Located Above Driver and Passenger
	: DOME LIGHT, CAB Door Activated and Push On-Off at Light Lens, Timed Theater Dimming, Integral to Overhead Console, Center Mounted
	: SUN VISOR (2) Padded Vinyl; 2 Moveable (Front-to-Side) Primary Visors, Driver Side with Toll Ticket Strap

<u>Code</u>	<u>Description</u>
16VSL	WINDSHIELD Heated, Single Piece
16WBY	ARM REST, RIGHT, DRIVER SEAT
16WJU	WINDOW, POWER (2) and Power Door Locks, Left and Right Doors, Includes Express Down Feature
16WLS	FRESH AIR FILTER Attached to Air Intake Cover on Cowl Tray in Front of Windshield Under Hood
16WSK	CAB REAR SUSPENSION Air Bag Type
16XJP	INSTRUMENT PANEL Wing Panel
16XWD	SUNSHADE, EXTERIOR Aerodynamic, Painted Roof Color; Includes Integral Clearance/Marker Lights
16XWJ	WINDSHIELD WIPER BLADES Snow Type
16XXC	COWL TRAY LID
16ZBB	ACCESS, CAB {Bustin} Driver & Passenger Sides, Two Aluminum, Self-Cleaning Steps (Bustin) Per Door, For Use with Regular & Extended Cabs
27DUK	WHEELS, FRONT {Accuride 29169} DISC; 22.5x8.25 Rims, Powder Coat Steel, 5-Hand Hole, 10-Stud, 285.75mm BC, Hub-Piloted, Flanged Nut, with .472" Thick Increased Capacity Disc and Steel Hubs
28DUK	WHEELS, REAR {Accuride 29169} DUAL DISC; 22.5x8.25 Rims, Powder Coat Steel, 5-Hand Hole, 10-Stud, 285.75mm BC, Hub-Piloted, Flanged Nut, with .472" Thick Increased Capacity Disc and Steel Hubs
29WAP	WHEEL GUARDS, FRONT {Accuride} for Metric Hub Piloted Wheels with Flanged Mounting Nuts Mounted Between Hub and Wheel
29WAR	WHEEL GUARDS, REAR {Accuride} for Metric Hub Piloted Wheels with Flanged Mounting Nuts, Mounted Between Hub & Wheel and Between Dual Wheels
29WLK	WHEEL BEARING, FRONT, LUBE {EmGard FE-75W-90} Synthetic Oil
60AAG	BDY INTG, REMOTE POWER MODULE Mounted Inside Cab behind Driver Seat; Up to 6 Outputs & 6 Inputs, Max. 20 amp. per Channel, Max. 80 amp Total (Includes 1 Switch Pack with Latched Switches)
7482133264	(2) TIRE, FRONT 11R22.5 Load Range H XDN2 (MICHELIN), 497 rev/mile, 75 MPH, Drive
7482133264	(4) TIRE, REAR 11R22.5 Load Range H XDN2 (MICHELIN), 497 rev/mile, 75 MPH, Drive
	Cab schematic 100WK
	Location 1: 9219, Winter White (Std)
	Chassis schematic N/A
	<b>Services Section:</b>
40128	WARRANTY Standard for HV507, HV50B, HV607 Models, Effective with Vehicles Built July 1, 2017 or Later, CTS-2025A
40SLG	SRV CONTRACT, EXT CMMS ENGINE {Cummins} To 60-Month/100,000 Miles (160,000 km), Extended Cummins L9 Engine Coverage, Protection Plan 1
Program Locks	Turn door locks off



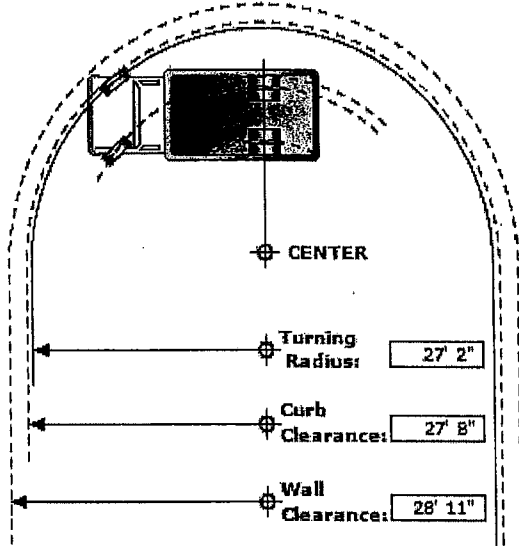

Series: HV  
 Model: HV507  
 Description: HV507 SFA  
 Model Year: 2020

**Calculation Factors**

Wheelbase: 189  
 Front Axle: 0002ARV  
 Description: AXLE, FRONT NON-DRIVING, {Meritor MFS-14-143A} Wide Track, I-Beam Type, 14,000-lb Capacity  
 Front Wheel: 0027DUK  
 Description: WHEELS, FRONT, {Accuride 29169} DISC; 22.5x8.25 Rims, Powder Coat Steel, 5-Hand Hole, 10-Stud, 285.75mm BC, Hub-Piloted, Flanged Nut, with .472" Thick Increased Capacity Disc and Steel Hubs  
 Front Tire: 07482133264  
 Description: TIRES, 11R22.5 Load Range H XDN2 (MICHELIN), 497 rev/mile, 75 MPH, Drive  
 Steering Gear: 0005PSA  
 Description: STEERING GEAR, {Sheppard M100} Power

**Turning Radius Statistics**

General Information

Inside Turn Angle: 45 Degrees  
 Radial Overhang: 21

Axle Information

KingPin Inclination: 6.25 Degrees  
 KingPin Center: 71.5

**Turning Radius - Curb View**

C - Curb Contact Length: 15.89  
 CI - Curb Clearance Increment: 5.98  
 CR - Curb Clearance Radius: 27'8"  
 CH - Curb Height: 6"  
 TR - Turning Radius: 27'2"  
 TW - Tire Width: 11.20

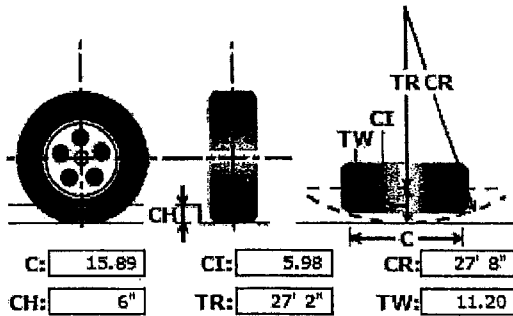

\* All Measurements are in inches, unless otherwise specified.

This information is based on engineering information available at this time. Actual figures may vary. Navistar, Inc. cannot accept liability for consequences due to this variance.



**HAWKEYE TRUCK EQUIPMENT**

5800 - 2ND AVENUE, P.O. BOX 3283  
 DES MOINES, IOWA 50316-0283  
 1-800-822-8223 • 515-289-1765

" The Complete Truck Equipment Center "

Job No.	20973
Quote Date	09/18/18
Expire Date	10/18/18

Customer: 532000  
 O'HALLORAN INTERNATIONAL  
 P O BOX 1804  
  
 DES MOINES IA 50305-1804

Payments by Credit Card may be subject to 3% handling fee.

Terms				
N10				
TH. Order Trk				

DALLAS CENTER SINGLE AXLE 2019

\*\*\*\*\*  
 ATTN: BOB KAYSER PH; 967-3300

- 1-DURA CLASS 11' AR400 STEEL DUMP BODY INSTALLED & PAINTED WHITE
- 1-DURA CLASS 1821 UNDERBODY SCISSORS STYLE HOIST
- AIR TAILGATE, 4' FLAT FLOOR WITH 20" RADIUS SIDES, REAR STROBES, I BEAM LONGSILLS, 30" TALL SIDES, 36" TALL TAILGATE, NO CABSHEILD.
- 1-FOLD DOWN LADDER INSTALLED ON DRIVERS SIDE REAR

*— Combo Pintle / 2 5/16" ball*

HEAVY DUTY REAR HITCH WITH A PH20 PINTLE INCORPORATED WITH REAR WING MOUNT

- 1-STAINLESS STEEL "COMBO" STATIONARY CAB SHEILD/RESERVOIR/VALVE ENCLOSURE
- 40 GALLON STAINLESS STEEL RESERVOIR INSTALLED BEHIND THE CAB
- STAINLESS STEEL VALVE ENCLOSURE INSTALL ON CAB SHEILD ON STREET SIDE
- 360 DEGREE AMBER STROBE LIGHT PACKAGE ( INSTALLED IN THE CAB SHEILD AND REAR )
- HMV MANIFOLD STYLE HYDRAULIC VALVE MOUNTED IN THE ENCLOSURE
- ALL SECTIONS TO BE AIR ACTUATED WITH SLAVE CYLINDER FEATURE
- ALL AIR CONTROLS IN TH CAB TO BE INSTALLED IN SEAT CONSOLE, FLOOR MOUNTED
- P.T.O. DRIVEN PISTON PUMP, SLIM LINE DESIGN TO DIRECT MOUNT

- LOW PROFILE POLK COUNTY STYLE FRONT QUICK HITCH ( TRUCK PORTION ONLY )
- MP36R11-ISCT MONROE PLOW, DEFLECTOR, PARKING JACK, MARKERS, QUICK HITCH
- AND MAIL BOX TRIM, L.E.D. PLOW LIGHTS INSTALLED TO FENDER MOUNTED TRUCK MIRRORS

\*\*\* CONTINUED NEXT PAGE \*\*\*



**HAWKEYE TRUCK EQUIPMENT**

5800 - 2ND AVENUE, P.O. BOX 3283  
 DES MOINES, IOWA 50316-0283  
 1-800-622-8223 - 515-289-1766

" The Complete Truck Equipment Center "

Job No.	20973
Quote Date	09/18/18
Expire Date	10/18/18

Customer: 532000

O' HALLORAN INTERNATIONAL  
 P O BOX 1804

DES MOINES IA 50305-1804

Payments by Credit Card may be subject to 3% handling fee.

Terms				
N10				
H. Order No.				

8' MONROE REAR MOUNT WING, PARA GLIDE FRONT POST, DUAL PUSH ARMS, DECELL CYLINDER, WING LOCK, REAR MOUNT TO FIT BEHIND THE DUALS

MONROE HEAVY DUTY FIXED ANGLE UNDERBODY SCRAPER

(4) CLEAR SPOT LIGHTS INSTALLED FOR WING, SCRAPER, AND 2 FOR SANDER

1-MONROE STAINLESS STEEL TAILGATE SANDER, DIRECT DRIVE, NON GROUND SPEED

6" AUGER, REVERSE FLIGHT, SELF LEVELING SPINNER.

1-SET OF INSTA CHAINS INSTALLED FOR A SINGLE AXLE SPRING RIDE CHASSIS

1-11' X 8' X 1/2" HWM PLASTIC LINER

\$ 97,556.00

THANK YOU FOR THE OPPORTUNITY, TIM HESSELTINE

Sub total	\$	0.00
Sales Tax	\$	0.00
Freight	\$	0.00
FET	\$	0.00
Total	\$	0.00



**VEENSTRA & KIMM, INC.**

3000 Westown Parkway West Des Moines, Iowa 50266-1320  
 515-225-8000 515-225-7848(FAX) 800-241-8000 (WATS)

Date: April 4, 2019

PAY ESTIMATE NO. 1

Project Title	Water Treatment Plant Backwash Improvements Dallas Center, Iowa		Contractor	Thorpe Water Development 1485 NE 70th Avenue Ankeny, IA 50023
Original Contract Amount & Date	\$161,350.00	November 13, 2018	Pay Period	November 13, 2018 - April 3, 2019

**BID ITEMS**

	Description	Unit	Estimated Quantity	Unit Price	Extended Price	Quantity Complete	Value Completed
<b>DIVISION 1</b>							
1.1	Mobilization	LS	1	\$ 8,500.00	\$ 8,500.00		\$ -
1.2	Surface Restoration	LS	1	\$ 4,500.00	\$ 4,500.00		\$ -
1.3	Backwash Water Storage Piping Manifold	LS	1	\$ 65,000.00	\$ 65,000.00		\$ -
1.4	Low Pressure Sanitary Sewer Lift Station	Ea.	1	\$ 37,850.00	\$ 37,850.00		\$ -
1.5	Granular Surfacing	TONS	50	\$ 50.00	\$ 2,500.00		\$ -
1.6	Curb Removal and Replacement	LF	50	\$ 110.00	\$ 5,500.00		\$ -
<b>DIVISION 2</b>							
2.1	Mobilization	LS	1	\$ 3,500.00	\$ 3,500.00	1	\$ 3,500.00
2.2	Traffic Control	LS	1	\$ 3,500.00	\$ 3,500.00	1	\$ 3,500.00
2.3	Surface Restoration	LS	1	\$ 3,500.00	\$ 3,500.00		\$ -
2.4	2" Force Main Sanitary Sewer Directionally Bored in Place	LF	1550	\$ 12.00	\$ 18,600.00	1542	\$ 18,504.00
2.5	2" Force Main Sanitary Sewer Under Highway	LF	60	\$ 65.00	\$ 3,900.00	60	\$ 3,900.00
2.6	Connection to Existing Low Pressure Sanitary Sewer	Ea.	1	\$ 4,500.00	\$ 4,500.00	1	\$ 4,500.00
	<b>TOTAL CONTRACT</b>				\$ 161,350.00		\$ 33,904.00

**MATERIALS STORED SUMMARY**

Description	Number of Units	Unit Price	Extended Cost
Backwash Water Storage Piping Manifold	1	\$ 34,659.75	\$ 34,659.75
			\$ -
			\$ -
			\$ -
			\$ -
			\$ -
			\$ -
			\$ -
			\$ -
			\$ -
			\$ -
			\$ -
			\$ -
			\$ -
			\$ -
			\$ -
			\$ -
			\$ -
			\$ -
			\$ -
			\$ -
			\$ -
			\$ -
			\$ -
			\$ -
			\$ -
			\$ -
			\$ -
			\$ -
			\$ -
			\$ -
			\$ -
			\$ -
			\$ -
			\$ -
			\$ -
			\$ -
			\$ -
<b>TOTAL MATERIALS STORED</b>			<b>\$ 34,659.75</b>

### SUMMARY

		Contract Price	Value Completed
Original Contract Price		\$161,350.00	\$ 33,904.00
Approved Change Orders (list each)			
TOTAL ALL CHANGE ORDERS		\$ -	\$ -
Revised Contract Price		\$ 161,350.00	\$ 33,904.00
		Materials Stored	\$ 34,659.75
Value of Completed Work and Materials Stored		\$	68,563.75
		Less Retained Percentage (5%)	\$ 3,428.19
Net Amount Due This Estimate		\$	65,135.56
Less Estimate(s) Previously Approved	No.1		
	No.2		
	No.3		
	No.4		
	No.5		
	No.6		
	No.7		
	No.8		
	No.9		
	No.10		
	No.11		
	No.12		
Less Total Pay Estimates Previously Approved		\$	-
		Amount Due This Estimate	\$ 65,135.56

The amount \$ 65,135.56 is recommended for approval for payment in accordance with the terms of the contract.

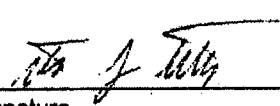
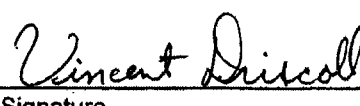
<b>Quantities Complete Submitted By:</b> Thorpe Water Development   Signature	<b>Recommended By:</b> Veenstra & Kimm, Inc.   Signature  Project Manager	<b>Approved By:</b> City of Dallas Center   Signature
Title  VP  Date 4/4/19	Title  Project Manager  Date 4-4-2019	Title   Date



# INVOICE

1830 Craig Park Court  
St. Louis, MO 63146

## RECEIVED

MAR 15 2019

## SCANNED

Date     /     /     By    

Invoice #	8073
Invoice Date	3/14/19
Account #	097631
Sales Rep	PAUL HUTTON
Phone #	515-986-4000
Branch #223	Grimes, IA
Total Amount Due	\$2,584.15

Bill To	CORE & MAIN LP
	PO BOX 28330
	ST LOUIS, MO 63146

THORPE WATER DEVELOPMENT CO  
PO BOX 555  
ANKENY IA 50021-0555

000/0000  
00000

Shipped To:  
HWY 44 WATER TREATMENT PLANT  
TOMMY 515-707-1255  
DALLAS CENTER, IA

CUSTOMER JOB- WTP DALLAS CENTER

Thank you for the opportunity to serve you! We appreciate your prompt payment.

Date Ordered	Date Shipped	Customer PO #	Job Name	Job #	Bill of Lading	Shipped Via	Invoice#
2/22/19	3/13/19	42724	DALLAS CENTER	WTP		CORE & MAIN LP	K187119

Product Code	Description	Quantity		Price	UM	Extended Price
		Ordered	Shipped			

X 04082614	8 PVC SDR26 HW SWR PIPE (G) 14' BID SEQ# 50	84	84	4.50000 FT		378.00
65R834	R834 8-3/4 SHELL CUTTER BID SEQ# 90	1	1	250.00000 EA		250.00
X 76MS1208PS601156	PRES SEAL 12-08 PSX:DD 601-156 8.0-8.65 OD & (1) BID SEQ# 100	1	1	55.00000 EA		55.00
X 2708T08GG26	8X8 HW SWR SDR26 TEE GXGXG BID SEQ# 110	4	4	95.00000 EA		380.00
X 27089GG26	8 HW SWR SDR26 90 GXG BID SEQ# 120	2	2	115.00000 EA		230.00
X 27084GG26	8 HW SWR SDR26 45 GXG BID SEQ# 130	1	1	65.00000 EA		65.00
X 65R412	R412 4-1/2 SHELL CUTTER BID SEQ# 160	1	1	225.00000 EA		225.00
X 0504040	4 SCH40 PVC PIPE SWB 20' BID SEQ# 170	20	20	1.75000 FT		35.00
X 27049HSDWV	4 PVC SCH40 DWV 90 HXSP BID SEQ# 180	3	3	9.50000 EA		28.50
X 27049HHDWV	4 PVC SCH40 DWV 90 HXH BID SEQ# 190	3	3	5.75000 EA		17.25
X 2904080FHVS	4 PVC S80 VANSTONE FLG SW BID SEQ# 200	6	6	17.50000 EA		105.00
X 96BUGSCREEN	12" X 12" #304 SS MESH SCREEN STAINLESS STEEL / BUG SCREEN BID SEQ# 210	3	3	25.00000 EA		75.00

6 1368.75



CORE & MAIN

# INVOICE

1830 Craig Park Court  
St. Louis, MO 63146

Invoice # 186229  
Invoice Date 3/07/19  
Account # 097631  
Sales Rep PAUL HUTTON  
Phone # 515-986-4000  
Branch #223 Grimes, IA  
Total Amount Due \$1,476.60

## SCANNED

Date     /     /     By    

## RECEIVED

Remit To  
CORE & MAIN LP  
PO BOX 28330  
ST LOUIS, MO 63146

THORPE WATER DEVELOPMENT CO  
PO BOX 555  
ANKENY IA 50021-0555

000/0000  
00000

MAR 08 2019

Shipped To:  
HWY 44 WATER TREATMENT PLANT  
TOMMY 515-707-1255  
DALLAS CENTER, IA

CUSTOMER JOB- WTP DALLAS CENTER

Thank you for the opportunity to serve you! We appreciate your prompt payment.

Date Ordered	Date Shipped	Customer PO #	Job Name	Job #	Bill of Lading	Shipped Via	Invoice#
2/22/19	2/22/19	42724	DALLAS CENTER	WTP		DIRECT	K186243

Product Code	Description	Quantity		B/O	Price	UM	Extended Price
		Ordered	Shipped				

CORE & MAIN PO#- 9091405

X/15015612027	60 HP DW WTIB SLD 20' BID SEQ# 40	120	120		112.00000	FT	.00
✓/26015612029	60X8 INSERTA TEE 8P35N12EP BID SEQ# 80	6	6		175.00000	EA	1,050.00
X/26015612030	60X4 INSERTA TEE 4IPS60HP BID SEQ# 150	3	3		110.00000	EA	330.00
X/26015618122	60" DW HP END CAP (IB SPIGOT)	3	3		3075.00000	EA	.00
X/26015618123	60" DW HP END CAP (BELL END)	3	3		3075.00000	EA	.00

OK - JTT  
3/11/19

1380.00

Freight    Delivery    Handling    Restock    Misc

Subtotal: 1,380.00  
Other: .00  
Tax: 96.60

Terms: NET 30  
Ordered By: TOMMY

Invoice Total: \$1,476.60

This transaction is governed by and subject to Core & Main's standard terms and conditions, which are incorporated by reference and accepted. To review these terms and conditions, please visit: <http://tandc.coreandmain.com/>

CORE & MAIN

# INVOICE

1830 Craig Park Center  
St. Louis, MO 63146

## RECEIVED

MAR 15 2019

Backordered from:

# SCANNED

Date 3/15/19 By [Signature]

THORPE WATER DEVELOPMENT CO 00070000  
PO BOX 555 00000  
ANKENY IA 50021-0555

Invoice # [Redacted]  
Invoice Date 3/14/19  
Account # 097631  
Sales Rep PAUL HUTTON  
Phone # 515-986-4000  
Branch #223 Grimes, IA  
Total Amount Due \$24,930.10

Remit To:  
CORE & MAIN LP  
PO BOX 28330  
ST LOUIS, MO 63146

Shipped To:  
HWY 44 WATER TREATMENT PLANT  
TOMMY 515-707-1255  
DALLAS CENTER, IA

CUSTOMER JOB- WTP DALLAS CENTER

Thank you for the opportunity to serve you! We appreciate your prompt payment.

Date Ordered	Date Shipped	Customer PO #	Job Name	Job #	Bill of Lading	Shipped Via	Invoice #
2/22/19	3/13/19	42724	DALLAS CENTER	WTP		DIRECT	K264998

Product Code	Description	Quantity		B/O	Price	UM	Extended Price
		Ordered	Shipped				

	CORE & MAIN PO#-	9091405					
/15015612027	60 HP DW WTIB SLD 20' BID SEQ# 40	120	40	80	112.00000	FT	4,480.00
/26015618122	60" DW HP END CAP (IB SPIGOT)	3	3		3075.00000	EA	9,225.00
/26015618123	60" DW HP END CAP (BELL END)	3	3		3075.00000	EA	9,225.00

422,930.10

Freight Delivery Handling Restock Misc

Subtotal: 22,930.00  
Other: .00  
Tax: 1,605.10

Terms: NET 30  
Ordered By: TOMMY

Invoice Total: \$24,535.10

This transaction is governed by and subject to Core & Main's standard terms and conditions, which are incorporated by reference and accepted. To review these terms and conditions, please visit: <http://tsndc.coreandmain.com/>



# INVOICE

1830 Craig Park Court  
St. Louis, MO 63116

Invoice # K265005  
Invoice Date 3/14/19  
Account # 097631  
Sales Rep PAUL HUTTON  
Phone # 515-986-4000  
Branch #223 Grimes, IA  
Total Amount Due \$9,587.20

## RECEIVED

MAR 15 2019

Backordered from:  
3/07/19 K186243

Remit To:  
CORE & MAIN LP  
PO BOX 28330  
ST LOUIS, MO 63146

THORPE WATER DEVELOPMENT CO  
PO BOX 555  
ANKENY IA 50021-0555

000/8800  
00590

Shipped To:  
HWY 44 WATER TREATMENT PLANT  
TOMMY 515-707-1255  
DALLAS CENTER, IA

# SCANNED

*AK'd JTT  
3/18/19*

Date     /     /     By    

CUSTOMER JOB- WTP DALLAS CENTER

Thank you for the opportunity to serve you! We appreciate your prompt payment.

Date Ordered	Date Shipped	Customer PO #	Job Name	Job #	Bill of Lading	Shipped Via	Invoice#
2/22/19	3/12/19	42724	DALLAS CENTER	WTP		DIRECT	K265005

Product Code	Description	Quantity		Price	UM	Extended Price
		Ordered	Shipped			

CORE & MAIN PO#- 9091405

/15015612027

60 HP DW WTIB SLD 20'	80	80	112.00000 FT	8,960.00
BID SEQ# 40				

*8960*

Freight    Delivery    Handling    Restock    Misc

Subtotal: 8,960.00  
Other: .00  
Tax: 627.20

Terms: NET 30  
Ordered By: TOMMY

Invoice Total: \$9,587.20

This transaction is governed by and subject to Core & Main's standard terms and conditions, which are incorporated by reference and accepted. To review these terms and conditions, please visit: <http://tandc.coreandmain.com/>



# INVOICE

## RECEIVED

1830 Craig Park Court  
St. Louis, MO 63146

MAR 15 2019

SCANNED  
Date / / By

Invoice Date	3/14/19
Account #	097631
Sales Rep	PAUL HUTTON
Phone #	515-986-4000
Branch #223	Grimes, IA
Total Amount Due	34,859.28

Remit To	CORE & MAIN LP
	PO BOX 28330
	ST LOUIS, MO 63146

THORPE WATER DEVELOPMENT CO      000/0000  
 PO BOX 555                                      00000  
 ANKENY IA 50021-0555

Shipped To:  
 HWY 44 WATER TREATMENT PLANT  
 TOMMY 515-707-1255  
 DALLAS CENTER, IA

CUSTOMER JOB- WTP      DALLAS CENTER

Thank you for the opportunity to serve you! We appreciate your prompt payment.

Date Ordered	Date Shipped	Customer PO #	Job Name	Job #	Bill of Lading	Shipped Via	Invoice #
2/22/19	3/13/19	42724	DALLAS CENTER	WTP		CORE & MAIN LP	K187119

Product Code	Description	Quantity		Price	UM	Extended Price
		Ordered	Shipped			

Product Code	Description	Quantity		Price	UM	Extended Price
		Ordered	Shipped			
X 24AFGFR04A	4X1/8 FLG FF RR GASKET BID SEQ# 220	3	3	1.25000	EA	3.75
X 24AFBNKS04304	4 304SS HEX BOLT & NUT KIT BID SEQ# 230	3	3	5.75000	EA	17.25
0910M021190	2 IPS DR11 HDPE 90 BEND MOLD BID SEQ# 310	1	1	4.75000	EA	4.75
0910M021.511R	2X1-1/2 1000 SDR11 IPS PE RED BID SEQ# 320	1	1	7.75000	EA	7.75
09PE01.511TFS	1-1/2" SDR11 TRANS FTG-SS BID SEQ# 330	1	1	16.00000	EA	16.00
96TWBOXS	TRACER WIRE ACCESS BOX (SEWER) BID SEQ# 350	1	1	35.00000	EA	35.00
96DBWIRE12GHDD500	12GA EHS HDD WIRE 500' GREEN 1245G-EHS-500-XTRA HI STRENGTH	2000	2000	.25000	FT	500.00
6590220	DRYCONN 90220 DIRECT BURY LUG 3 WAY CONNECTOR BLUE BID SEQ# 370	2	2	10.00000	EA	20.00
14GR0608EFT	5/8" X 8' ELECT GROUND ROD BID SEQ# 380	1	1	18.50000	EA	18.50
96GCLAMP05	5/8" GROUND CLAMPS ONLY #G5 BID SEQ# 390	1	1	2.50000	EA	2.50
020618CLRJIB	6 C900 DR18 CERTALOK PIPE IB BID SEQ# 430	60	60	7.75000	FT	465.00
/80015612031	2.375"X6.134" SS CASING SPACER CENTER RESTRAINED, 8" WIDTH FOR 0.383" THICK CASING PIPE BID SEQ# 460	12	12	40.00000	EA	480.00

821

## RESOLUTION NO. 2019-8

### RESOLUTION DESIGNATING THE FORMER HOOVER LUMBERYARD PROPERTY AS CITY PARK SPACE AND NAMING IT HERITAGE PARK

**WHEREAS**, in 2014 the City of Dallas Center (the "City") purchased and now owns the property formerly known as the Hoover Lumberyard located northeast of the intersection of Walnut Street and Fourteenth Street, and legally described as Lot A of Block Forty-four (44) of the Original Town of Dallas Center, Dallas County, Iowa, together with Spur Track I.C.C. #7 of the Chicago and Northwest Railway Company; and

**WHEREAS**, the Parks and Recreation Board has recommended that the City-owned property formerly known as the Hoover Lumberyard be designated as City park space and be named "Heritage Park".

**NOW, THEREFORE, IT IS RESOLVED** by the Council of the City of Dallas Center, Iowa, that the City-owned property formerly known as the Hoover Lumberyard be designated as City park space and that it be named Heritage Park.

**PASSED, APPROVED, AND ADOPTED** by the City Council of the City of Dallas Center, Iowa, on this 9<sup>th</sup> day of April, 2019.

---

Michael A. Kidd, Mayor

ATTEST:

---

Cindy Riesselman, City Clerk



**DALLAS CENTER**  
{ *Quietly* PROGRESSIVE }

Our City previously supported the Raccoon River Valley Trail (RRVT) application to the Iowa Department of Cultural Affairs for designation as an “Iowa Great Place”; recognizing the efforts of a local group of communities taking action to enhance the trail while retaining the historic and unique features of the railroad bed on which it resides.

Since the designation has expired, we offer our support to the Adel Partners Chamber for the application to re-designate the RRVT as an “Iowa Great Place”.

The RRVT, which comprises more than 89 miles of paved surface, for bicycling, running, and other forms of recreational activities is a highly valued public resource, which enriches our community and provides health and recreation benefit to residents of all ages, abilities and socio-economic backgrounds.

In conclusion, the City of Dallas Center does hereby support the regional collaboration among the 14 communities on the RRVT trail for the purposes of economic and cultural development and does heartily endorse the application for re-designation of the RRVT as an “Iowa Great Place”.

---

Mike Kidd  
Mayor

Attest: \_\_\_\_\_  
Cindy Riesselman  
City Clerk

**CITY HALL**

1502 Walnut St, PO Box 396, Dallas Center, Iowa 50063 | p 515.992.3725 | f 515.992.3764 | cityhall@dallascenter.com  
dallascenter.com